

Type SQBA

Belt Drive Square In-Line Centrifugal Fans



AMERICAN COOLAIR CORPORATION

P.O. Box 2300 Jacksonville, Florida 32203
 Phone: (904) 389-3646
 Fax: (904) 387-3449 • (904) 381-7560
 E-mail: fans@coolair.com
 Internet: www.coolair.com

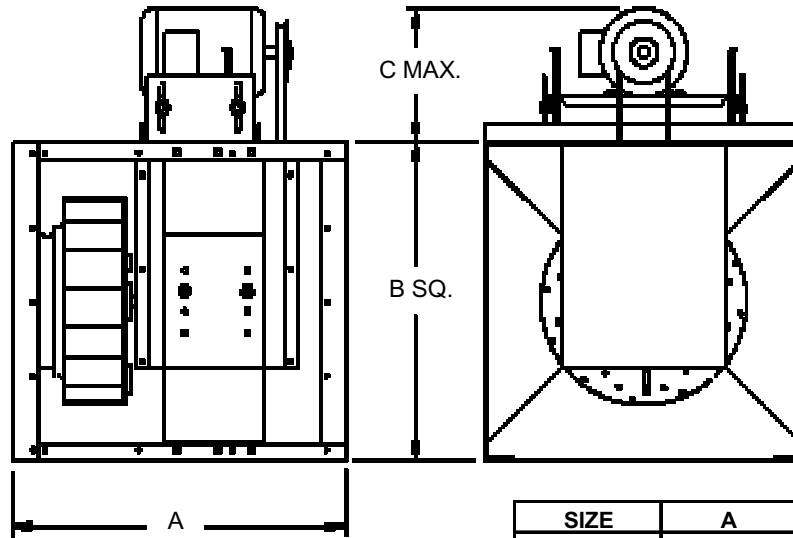

Standard Fan Features

- Non-overloading aluminum wheel computer balanced
- Removable panels on 3 sides
- Galvanized outer skin
- Rigid internal cross-bracing
- Variable pitch motor pulley
- NEMA Standard open drip-proof motors
- Overlapping wheel/inlet venturi
- Heavy duty self-aligning pillow-block bearings with cast iron housing
- AMCA label for air and sound
- UL Listed for Standard 705 (most models)

Optional Features

- Disconnect switch (loose or factory mounted and wired)
- Backdraft damper
- Vibration isolators
- Epoxy coating
- Inlet and outlet flanges
- Duct connector (most sizes)
- Variable inlet vanes for flow control
- Motor cover
- Drive guard
- Internal insulation
- Inlet and outlet guards

SIZE	A	B	C
06-10	17	14	10 ^{3/4}
12	25 ^{3/4}	18	16 ^{5/8}
13	26 ^{3/8}	20	16 ^{5/8}
15	27 ^{7/8}	23	16 ^{5/8}
16	27 ^{3/8}	25 ^{1/2}	16 ^{5/8}
18	27 ^{1/4}	28 ^{1/2}	16 ^{5/8}
20	28 ^{3/4}	30 ^{1/2}	16 ^{5/8}
24	36 ^{5/8}	36 ^{1/2}	16 ^{3/4}
30	39 ^{1/4}	45 ^{1/2}	17 ^{5/8}
36	42 ^{5/8}	56	17 ^{5/8}

Dimensions in inches

Specifications

		FAN DATA					MOTOR DATA						
FAN NO.	QTY.	MODEL NO.	CFM	SP	RPM	SONES	HP	RPM	VOLTAGE	PH	HZ	ENCLOSURE	ACCESSORIES AND REMARKS

PROJECT _____ ENGINEER _____ SUBMITTED BY _____ DATE _____
 LOCATION _____ CONTRACTOR _____ APPROVED BY _____ DATE _____