

cincinnati fan

OEM and Industrial Air Handling Specialist



SPB

SERIES

PRESSURE BLOWERS

7697 Snider Road, Mason, OH 45040-9135

Telephone: 513-573-0600

Visit us at www.cincinnati.com for more information.

Cat. No. SPB-1006
Supersedes SPB-401



Cincinnati fan

A Company That Stands Behind Its Product

Since the founding of **Cincinnati Fan** in 1956, the company's mission has been to provide quality products at competitive prices, backed by dependable service.

This mission is carried out by specializing in the market for industrial air handling products up to 125 HP. But specialization does not mean the product line is small. **Cincinnati Fan** offers a wide variety of standard and customized products, production flexibility, and customer responsiveness.

Cincinnati Fan has over 170 experienced sales engineers across the U.S. and Canada ready to serve your air handling needs.

Cincinnati Fan can provide:

- Technical evaluation for correct performance conditions.
- Review of air stream and ambient conditions that require special attention.
- Selection of proper components to meet required design specifications.
- Selection of proper accessories.
- System analysis for proper fan design.

Cincinnati Fan operates in a modern facility specifically designed for world class manufacturing enabling us to build standard products to order, including accessories, and ship within 5 to 15 working days.

With support like this, you can be sure your **Cincinnati Fan** product will be well-built and will provide maximum dependability and longevity.

Visit us at www.cincinnati-fan.com for more information.

SPECIFICATIONS FOR SPB SERIES

Radial bladed pressure blower shall be Cincinnati Fan SPB Series, Model _____, Arrangement _____, Capacity: _____ CFM, _____ Static Pressure at standard conditions. Operating conditions: _____ °F, _____ Ft. Altitude.

Wheels shall be 319 or 356T6 cast aluminum with integral cast hub and blades. Blower housing shall be 14 gauge stamped steel with round inlet and discharge for connection to hose or duct without using a transition piece. Blower housing to have a baked, powder coated, high gloss, black enamel finish inside and out.

Fan motor and fan bearing vibration levels shall not exceed 1.5 mils displacement at 3450 RPM. Shafts shall be turned, ground and polished steel (or stainless steel). All fan shafts shall receive a rust preventive coating prior to shipment.

Fan bearings shall be grease lubricated, heavy duty, self-aligning ball bearings mounted in cast iron pillow blocks. V-belt drives shall be selected for a minimum of 1.3 times nominal horsepower.

Fan construction shall be AMCA Type C spark-resistant or AMCA Type B spark-resistant if an aluminum ring is added around the fan/motor shaft.

The following accessories shall be included: (See page 4 for available accessories).

9 STANDARD ARRANGEMENTS



Arrangement 4
(Foot & flange motor)



Arrangement 4
(Flange mount-footless motor)



Arrangement 4
(Foot mounted motor)



Arrangement 4HM
(Horizontal mount)
(See pages 12 and 13)



Arrangement 1



Arrangement 2



Arrangement 8
(Model PB shown)

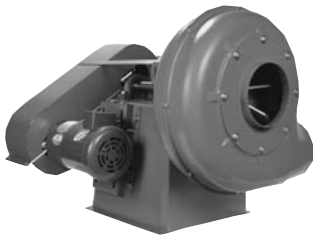

Arrangement 9



Arrangement 4D
(Double blower unit)

NOTE:

The SPB model photos in this catalog were taken with the blower housings painted in machine gray to show more detail. The actual blower housings have a baked-on, high gloss, black, powder coating inside and out.

BLOWER WHEELS

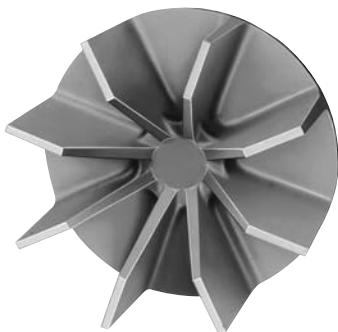

CAST ALUMINUM RADIAL

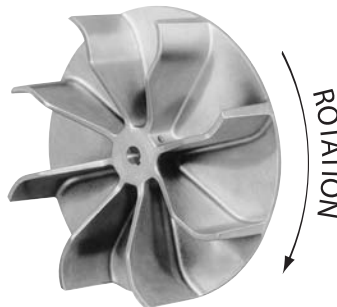

CAST ALUMINUM B.C.
(Backward Curve)



**OPTIONAL FABRICATED
STEEL or STAINLESS STEEL**
(Not available in B.C.)

All wheels have two set screws, 90°-120° apart, with one being over keyway. Up to 13" diameter wheels are statically balanced. Wheels over 13" in diameter are dynamically balanced. Use steel wheel for high abrasion. Stainless steel or coated wheels should be used in corrosive environments.

STANDARD FEATURES FOR ALL SPBs

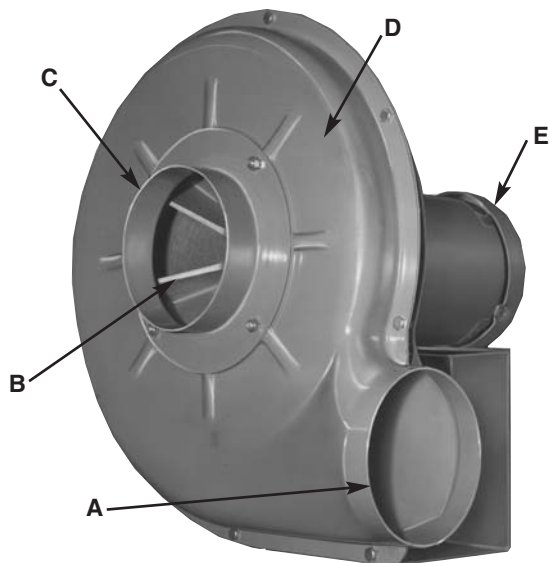

- A. Stamped housing design gives round outlet for easy flange, pipe or hose connection.
- B. Spark resistant cast aluminum wheels are standard. By adding aluminum rubbing ring to motor side of housing, blower will be AMCA Type B spark-resistant.
- C. Different size inlet collars available.
- D. Heavy duty 14 gauge steel housing with baked powder coated, high gloss, black enamel finish inside and out.
- E. Available in direct or belt driven arrangements #1, 2, 4, 4HM, 8 and 9.

OPTIONAL ACCESSORIES



Inlet/Outlet Flange

Cast aluminum drilled to ANSI-125 pound flange bolt circle dimensions if requested. **SPB-15 inlet flange is 10 gauge steel. Not available on some discharge positions. See page 15.**

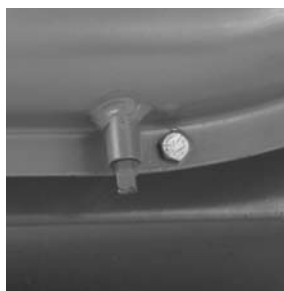

Drain Connection

1/8" pipe coupling, with plug, welded to lowest point of housing. Not required on BH discharge position.



Inlet Filters

Many layered fine wire mesh. Pleated paper media available on some sizes.



Slide Gate Damper

Available for 4, 5, 6, 7, 8 and 10 inch inlets or outlets. Cast aluminum frame, galvanized steel gate. Suitable for duct work. Dimensions on page 15. **Add inlet/outlet guard if not ducted. Not available on some discharge positions. See page 15.**



Teflon Shaft Seal

1/8" thick teflon shaft seal good to 400°F.



Belt Guard – Standard Arr. 9

Bearing side is enclosed. Not available unless Cincinnati Fan mounts motor. **Painted safety yellow.**



Inlet/Outlet Guard

Spiral guard with nickel/chrome/lacquer finish. OSHA type. Available on 4, 5, 6, 7, 8 and 10 inch inlets or outlets. **Required by OSHA on non-ducted inlet and/or discharge.**



Shaft and/or Heat Slinger Guard

Available on arrangement 1 and 9. Covers bearings and shaft between fan housing and belt guard. Has extended lube lines. Meets OSHA standards. **Painted safety yellow.**

SPARK-RESISTANT CONSTRUCTION

AMCA Type A: All parts in contact with airstream are of nonferrous material (See Model PB catalog).

AMCA Type B: Cast aluminum wheel and aluminum rubbing ring for motor or fan shaft. By adding aluminum rubbing ring to drive side of housing, the SPB Series is AMCA B spark-resistant. Maximum Temperature 400°F.

AMCA Type C: Standard on all SPB's. Cast aluminum wheels are standard. Maximum temperature 400°F.

WARNING

The use of aluminum or aluminum alloys in the presence of steel which has been allowed to rust requires special consideration. Research by the U.S. Bureau of Mines and others has shown that aluminum impellers rubbing on rusty steel may cause high intensity sparking.

The use of the above construction in no way implies a guarantee of safety for any level of spark resistance. Spark-resistant construction also does not protect against ignition of explosive gases caused by catastrophic failure or from any airstream material that may be present in a system.

HIGH TEMPERATURE CONSTRUCTION

Arrangements 2, 4 and 4HM

Up To 150°F: Standard fan construction.

151° - 400°F: Standard fan with heat slinger, slinger guard and teflon shaft seal. External hub on wheel or a shaft extension may be required (except on Arr. 2). Wheel is either high temperature cast aluminum or fabricated steel. **If wheel is fabricated steel, BC type wheels are not available.**

Arrangements 1, 8 and 9

Up To 200°F: Standard fan construction.

201° - 300°F: Standard fan with either high temperature cast aluminum wheel or fabricated steel wheel. **If wheel is fabricated steel, BC type wheels are not available.**

301° - 400°F: Standard fan with heat slinger and slinger guard. Wheel is either high temperature cast aluminum or fabricated steel. **If wheel is fabricated steel, BC type wheels are not available.**

401° - 750°F: See PBS models in PB catalog.

TEMPERATURE - ALTITUDE CONVERSIONS

Fan performance tables are developed using standard air which is 70°F., 29.92" barometric pressure and .075 lbs. per cubic foot. Density changes resulting from temperature and barometric pressure variations (such as high altitudes) must be corrected to standard conditions before selecting a fan based on standard performance data.

Temperature and/or altitude conversion factors are used in making corrections to standard conditions.

Temperature Limit

All SPB fans are limited to a maximum air temperature of 400°F. (204°C).

TEMPERATURE - ALTITUDE CONVERSIONS

AIR TEMP. F°	ALTITUDE IN FEET ABOVE SEA LEVEL										
	0	1000	2000	3000	4000	5000	6000	7000	8000	9000	10000
0°	.87	.91	.94	.98	1.01	1.05	1.09	1.13	1.17	1.22	1.26
40°	.94	.98	1.02	1.06	1.10	1.14	1.19	1.23	1.28	1.32	1.36
70°	1.00	1.04	1.08	1.12	1.16	1.20	1.25	1.30	1.35	1.40	1.45
80°	1.02	1.06	1.10	1.14	1.19	1.23	1.28	1.33	1.38	1.43	1.48
100°	1.06	1.10	1.14	1.19	1.23	1.28	1.33	1.38	1.43	1.48	1.54
120°	1.09	1.14	1.18	1.23	1.28	1.32	1.38	1.43	1.48	1.53	1.58
140°	1.13	1.18	1.22	1.27	1.32	1.37	1.42	1.48	1.54	1.58	1.65
160°	1.17	1.22	1.26	1.31	1.36	1.42	1.47	1.53	1.59	1.64	1.70
180°	1.21	1.26	1.30	1.36	1.41	1.46	1.52	1.58	1.64	1.70	1.75
200°	1.25	1.29	1.34	1.40	1.45	1.51	1.57	1.63	1.69	1.75	1.81
250°	1.34	1.39	1.45	1.50	1.56	1.62	1.68	1.74	1.82	1.88	1.94
300°	1.43	1.49	1.55	1.61	1.67	1.74	1.80	1.87	1.94	2.00	2.08
350°	1.53	1.59	1.65	1.72	1.78	1.85	1.92	2.00	2.07	2.14	2.22
400°	1.62	1.69	1.75	1.82	1.89	1.96	2.04	2.12	2.20	2.27	2.35

EXAMPLE:

Required fan performance is 2600 CFM at 5" SP at 160°F., and 8000 ft. altitude.

STEP 1: From the table, the conversion factor is 1.59.

STEP 2: Correct static pressure is 1.59 x 5"SP = 7.95"SP at standard conditions.

STEP 3: Make fan selection from table on page 6. We select an SPB-15 with 15 x 7 wheel and 8" inlet to deliver 2627 CFM at 8" SP.

STEP 4: Correct the BHP for the lighter air: 8.41 ÷ 1.59 = 5.29 BHP. A 7½ HP motor will suffice at 160°F. and 8000' altitude but not at standard conditions. Special motor insulation may be required above 3500' altitude. Also, BHP correction might need to be modified if blower will be subject to "cold starts," i.e: starting at 70°F. at 8000' altitude.



SPB SERIES DIRECT DRIVE RATING TABLES at 3450 RPM (Cont'd.)

CFM and BHP at Static Pressure Shown

Ratings at 70°F., .075 Density, Sea Level

MODEL NO.	WHEEL DIA. & WIDTH	INLET SIZE	9" SP		10" SP		11" SP		12" SP		13" SP		14" SP		15" SP		16" SP		
			CFM	BHP	CFM	BHP	CFM	BHP	CFM	BHP	CFM	BHP	CFM	BHP	CFM	BHP	CFM	BHP	CFM
SPB-12	12 x 2 ⁷ / ₈	6"	173	.91															
	12 x 2 ⁷ / ₈	5"	286	.86															
	12 ¹ / ₄ x 2 ⁷ / ₈	5"	420	1.17	262	.95													
	12 x 2 ⁷ / ₈	7"	440	1.50															
	13 x 3 ¹ / ₄ BC	5"	489	1.34	387	1.23													
	12 ¹ / ₄ x 2 ⁷ / ₈	6"	543	1.40	337	1.12													
	12 ¹ / ₄ x 2 ⁷ / ₈	7"	573	1.64	162	.95													
	13 x 3 ¹ / ₄	5"	596	1.41	519	1.27	407	1.10	212	.86									
	13 x 3 ¹ / ₄ BC	6"	613	1.57	473	1.43	137	.94											
	13 x 3 ¹ / ₄	6"	652	1.85	436	1.56	163	1.03											
13 x 3 ¹ / ₄ BC	7"	643	1.84	465	1.69	173	1.36												
13 x 3 ¹ / ₄	7"	832	2.38	674	2.16	343	1.74												
SPB-15	14 x 3 ¹ / ₄ BC	10"	679	2.07	307	1.89													
	14 x 3 ¹ / ₄ BC	6"	767	2.05	585	1.79	391	1.50											
	14 x 3 ¹ / ₄ BC	8"	781	2.06	583	1.80	347	1.49											
	14 x 3 ¹ / ₄	6"	1368	3.86	1152	3.40	883	2.81	547	2.00	182	1.19							
	14 x 3 ¹ / ₄	8"	1439	4.07	1167	3.41	889	2.75	570	2.06									
	14 x 3 ¹ / ₄	10"	1470	3.86	1213	3.35	894	2.81											
	15 ¹ / ₂ x 5 BC	6"	1429	4.05	1308	3.87	1176	3.68	1022	3.44	829	3.11	549	2.56	200	1.83			
	14 ¹ / ₄ x 6 ¹ / ₈	6"	1582	4.59	1421	4.24	1238	3.86	1034	3.43	814	2.96	586	2.45	349	1.94			
	15 ¹ / ₂ x 5 BC	10"	1671	4.47	1488	4.17	1291	3.88	1072	3.58	808	3.27	438	2.88					
	15 ¹ / ₂ x 5 BC	8"	1682	4.56	1494	4.24	1303	3.92	1108	3.61	903	3.27	676	2.90	396	2.44			
	14 ³ / ₄ x 4	6"	1768	5.57	1619	5.19	1448	4.76	1247	4.24	1009	3.64	728	2.96	399	2.20			
	16 ¹ / ₂ x 4 ³ / ₈ BC	6"	1681	4.98	1570	4.79	1451	4.60	1324	4.38	1188	4.16	1041	3.91	881	3.64	699	3.33	
	15 x 7	6"	1842	5.86	1726	5.59	1601	5.29	1462	4.97	1304	4.59	1119	4.13	889	3.51	597	2.69	
	16 ¹ / ₂ x 4 ³ / ₈ BC	8"	1940	5.65	1778	5.38	1614	5.10	1447	4.81	1277	4.51	1103	4.18	920	3.82	720	3.42	
	16 ¹ / ₂ x 4 ³ / ₈ BC	10"	1973	5.68	1809	5.39	1641	5.09	1466	4.80	1280	4.50	1074	4.18	831	3.85	489	3.41	
	14 ¹ / ₄ x 6 ¹ / ₈	8"	1947	5.77	1696	5.10	1436	4.43	1168	3.76	887	3.11	562	2.43					
	14 ¹ / ₄ x 6 ¹ / ₈	10"	1947	5.74	1723	5.11	1480	4.49	1192	3.88	755	3.13							
	15 ¹ / ₂ x 5	6"	1947	6.82	1831	6.50	1703	6.15	1559	5.74	1394	5.27	1202	4.72	978	4.10	726	3.43	
	14 ³ / ₄ x 4	8"	2097	6.44	1881	5.90	1646	5.31	1387	4.65	1094	3.88	741	2.96					
	14 ³ / ₄ x 4	10"	2131	6.51	1904	5.96	1661	5.37	1392	4.74	1074	4.04	584	3.12					
	16 ¹ / ₂ x 4 ³ / ₈	6"	2286	9.31	2177	8.98	2060	8.62	1934	8.21	1796	7.75	1643	7.22	1474	6.62	1283	5.94	
	15 x 7	8"	2455	7.91	2271	7.38	2072	6.81	1855	6.20	1615	5.54	1344	4.80	1026	3.95	608	2.92	
	15 x 7	10"	2541	8.22	2334	7.60	2115	6.95	1879	6.27	1619	5.55	1317	4.79	921	3.93	340	2.95	
	15 ¹ / ₂ x 5	8"	2550	8.76	2357	8.18	2149	7.57	1925	6.92	1682	6.21	1414	5.42	1114	4.55	760	3.55	
	15 ¹ / ₂ x 5	10"	2582	8.84	2373	8.19	2160	7.55	1938	6.90	1700	6.24	1431	5.53	1090	4.71			
	16 ¹ / ₂ x 4 ³ / ₈	8"	2915	11.17	2749	10.59	2579	10.01	2403	9.43	2219	8.83	2023	8.20	1811	7.53	1571	6.78	
16 ¹ / ₂ x 4 ³ / ₈	10"	3049	11.63	2841	10.91	2637	10.21	2435	9.51	2232	8.80	2021	8.07	1797	7.29	1546	6.44		

MODEL NO.	WHEEL DIA. & WIDTH	INLET SIZE	17" SP		18" SP		19" SP	
			CFM	BHP	CFM	BHP	CFM	BHP
SPB-15	15 ¹ / ₂ x 5	8"	256	2.38				
	15 x 7	6"	271	1.89				
	16 ¹ / ₂ x 4 ³ / ₈ BC	8"	471	2.95				
	16 ¹ / ₂ x 4 ³ / ₈ BC	6"	477	2.95				
	15 ¹ / ₂ x 5	6"	459	2.78	175	2.12		
	16 ¹ / ₂ x 4 ³ / ₈	6"	1070	5.19	831	4.39	546	3.52
	16 ¹ / ₂ x 4 ³ / ₈	8"	1282	5.89	881	4.66		
	16 ¹ / ₂ x 4 ³ / ₈	10"	1237	5.43	698	3.90	402	3.31

8 STANDARD DISCHARGE POSITIONS AVAILABLE. 45° DISCHARGE POSITIONS AVAILABLE AT EXTRA CHARGE.^H
Discharges shown are determined by viewing fan from motor or drive side.



CW-TH
Clockwise Top
Horizontal
Discharge



CW-DB
Clockwise
Down-Blast
Discharge



CW-BH
Clockwise
Bottom
Horizontal
Discharge



CW-UB
Clockwise
Up-Blast
Discharge



CCW-TH
Counter-
Clockwise Top
Horizontal
Discharge



CCW-DB
Counter-
Clockwise
Down-Blast
Discharge



CCW-BH
Counter-
Clockwise
Bottom
Horizontal
Discharge



CCW-UB
Counter-
Clockwise
Up-Blast
Discharge

^H Discharge flange or slide gate damper not available on some discharge positions. See page 15.



SPB SERIES BELT DRIVE RATING TABLES

Ratings at 70°F., .075 Density, Sea Level

NOTE: FOR RPM'S IN BOLD ITALICS, DIRECT DRIVE BLOWERS SHOULD BE CONSIDERED

SPB-9

Outlet Area (Sq. Ft.) 0.087

Wheel Size: 9" X 2⁷/₈"

INLET: 5"

VOLUME CFM	SP (IN.) WG																				
	1"		1 ¹ / ₂ "		2"		2 ¹ / ₂ "		3"		3 ¹ / ₂ "		4"		4 ¹ / ₂ "		5"		6"		
	RPM	BHP	RPM	BHP	RPM	BHP	RPM	BHP	RPM	BHP	RPM	BHP	RPM	BHP	RPM	BHP	RPM	BHP	RPM	BHP	
50	1536	.02	1867	.04	2149	.06	2398	.08	2625	.11	2833	.14	3028	.16	3211	.19	3384	.23			
100	1653	.04	1960	.06	2226	.08	2464	.11	2681	.13	2883	.16	3071	.19	3249	.22	3418	.26	3734	.33	
150	1841	.06	2119	.08	2365	.11	2589	.14	2795	.17	2987	.20	3168	.24	3339	.27	3502	.31	3808	.39	
200	2079	.09	2328	.12	2553	.15	2760	.19	2953	.22	3134	.26	3306	.29	3469	.33	3626	.37	3920	.46	
250	2350	.14	2572	.17	2777	.21	2968	.25	3147	.29	3317	.33	3479	.37	3634	.41	3783	.46			
300	2643	.20	2843	.24	3029	.28	3205	.33	3371	.37	3530	.42	3683	.47	3829	.52	3970	.56			
350	2951	.28	3132	.33	3303	.38	3465	.43	3619	.48	3767	.53	3910	.58							
400	3269	.39	3435	.44	3592	.50	3742	.56	3886	.61											
450	3596	.52	3748	.58	3894	.64															
500	3929	.68																			

SPB-12

Outlet Area (Sq. Ft.) 0.196

Wheel Size: 12¹/₄" X 2⁷/₈"

INLET: 7"

VOLUME CFM	SP (IN.) WG																			
	2"		3"		4"		5"		6"		7"		8"		9"		10"		12"	
	RPM	BHP	RPM	BHP	RPM	BHP	RPM	BHP	RPM	BHP	RPM	BHP	RPM	BHP	RPM	BHP	RPM	BHP	RPM	BHP
100	1548	.09	1892	.16	2181	.24	2436	.32	2666	.42	2877	.52	3074	.62	3258	.73	3432	.85	3756	1.10
200	1576	.13	1912	.21	2199	.31	2454	.41	2685	.51	2898	.63	3095	.75	3281	.88	3457	1.01	3784	1.29
300	1656	.19	1966	.29	2239	.39	2485	.51	2710	.63	2919	.76	3115	.89	3299	1.03	3474	1.18	3800	1.49
400	1782	.28	2065	.39	2317	.51	2548	.64	2763	.77	2963	.91	3153	1.06	3332	1.22	3503	1.38	3824	1.71
500	1938	.39	2197	.52	2431	.66	2647	.80	2848	.95	3038	1.11	3219	1.27	3391	1.44	3556	1.61	3867	1.98
600	2114	.54	2353	.69	2571	.85	2772	1.01	2962	1.18	3141	1.35	3312	1.53	3476	1.72	3633	1.90	3932	2.30
700	2303	.73	2526	.90	2729	1.08	2919	1.27	3097	1.45	3267	1.65	3429	1.84	3585	2.04	3735	2.25		
800	2503	.96	2710	1.16	2902	1.36	3080	1.57	3249	1.78	3410	1.99	3564	2.21	3713	2.43	3856	2.65		
900	2711	1.26	2905	1.48	3085	1.70	3254	1.93	3414	2.16	3568	2.39	3714	2.63	3856	2.87	3993	3.11		
1000	2927	1.62	3107	1.85	3277	2.10	3437	2.35	3590	2.60	3736	2.85	3876	3.11						
1100	3148	2.05	3316	2.30	3476	2.57	3628	2.84	3774	3.11	3913	3.39								
1200	3373	2.56	3531	2.83	3681	3.11	3826	3.40	3965	3.70										
1300	3602	3.16	3750	3.45	3892	3.74														
1400	3835	3.86	3973	4.15																

SPB-15

Outlet Area (Sq. Ft.) 0.349

Wheel Size: 15¹/₂" X 5"

INLET: 8"

VOLUME CFM	SP (IN.) WG																	
	2"		4"		6"		8"		10"		12"		14"		16"		18"	
	RPM	BHP	RPM	BHP	RPM	BHP	RPM	BHP	RPM	BHP	RPM	BHP	RPM	BHP	RPM	BHP	RPM	BHP
200	1203	.13	1685	.31	2057	.54	2370	.79	2647	1.08	2897	1.39	3127	1.73	3341	2.08	3542	2.46
400	1258	.22	1730	.46	2097	.74	2407	1.04	2681	1.37	2929	1.73	3158	2.11	3371	2.51	3571	2.93
600	1329	.33	1790	.65	2150	1.00	2456	1.36	2727	1.75	2973	2.16	3200	2.60	3411	3.05		
800	1415	.48	1861	.88	2214	1.30	2515	1.74	2783	2.20	3026	2.68	3251	3.17	3460	3.69		
1000	1514	.67	1942	1.16	2287	1.66	2583	2.18	2847	2.71	3087	3.26	3309	3.83	3517	4.41		
1200	1625	.91	2033	1.48	2368	2.07	2658	2.67	2918	3.29	3155	3.92	3374	4.56	3579	5.22		
1400	1746	1.22	2134	1.87	2457	2.54	2741	3.23	2995	3.93	3228	4.64	3445	5.37				
1600	1876	1.61	2243	2.33	2554	3.09	2830	3.86	3079	4.64	3308	5.44	3521	6.25				
1800	2012	2.08	2359	2.88	2659	3.72	2926	4.57	3169	5.44	3394	6.32						
2000	2154	2.65	2482	3.53	2769	4.44	3028	5.38	3265	6.33	3485	7.30						
2200	2300	3.33	2611	4.28	2886	5.27	3136	6.29	3367	7.32	3581	8.37						
2400	2450	4.13	2745	5.16	3009	6.22	3250	7.32	3474	8.43								
2600	2603	5.06	2883	6.17	3136	7.31	3369	8.48	3586	9.67								
2800	2758	6.14	3025	7.32	3268	8.53	3492	9.78										
3000	2916	7.37	3171	8.62	3403	9.91												

NOTE: DRIVE LOSSES ARE NOT INCLUDED IN BHP.
CONSULT FACTORY FOR SPEEDS HIGHER THAN THOSE SHOWN.



SPB SERIES DIRECT DRIVE RATING TABLES at 2850 RPM

NOTE: THESE RATINGS ARE FOR 50 CYCLE MOTORS ONLY.

CFM and BHP at Static Pressure Shown

Ratings at 70°F., .075 Density, Sea Level

MODEL NO.	WHEEL DIA. & WIDTH	INLET SIZE	1" SP		2" SP		3" SP		4" SP		5" SP		6" SP		7" SP		8" SP	
			CFM	BHP	CFM	BHP	CFM	BHP	CFM	BHP	CFM	BHP	CFM	BHP	CFM	BHP	CFM	BHP
SPB-9	8 x 2 ³ / ₄	4"	228	.15	171	.13												
	8 ¹ / ₂ x 2 ³ / ₄	4"	250	.20	194	.19	99	.15										
	9 x 2 ⁷ / ₈	4"	263	.23	212	.20	134	.16										
	8 x 2 ³ / ₄	5"	277	.17	199	.15												
	8 ¹ / ₂ x 2 ³ / ₄	5"	314	.23	238	.20	93	.15										
	9 x 2 ⁷ / ₈	5"	334	.25	265	.23	169	.19										
	9 ³ / ₄ x 2 ⁷ / ₈	4"	320	.32	278	.29	222	.25	125	.19								
	10 ⁵ / ₈ x 2 ⁵ / ₈	4"	357	.41	326	.37	280	.33	213	.28	87	.21						
	9 ³ / ₄ x 2 ⁷ / ₈	5"	395	.35	335	.32	267	.28	164	.22								
10 ⁵ / ₈ x 2 ⁵ / ₈	5"	440	.43	389	.40	332	.36	257	.30									
SPB-12	11 x 3 BC	5"	525	.44	457	.41	379	.37	265	.32								
	11 x 2 ³ / ₄	5"	601	.67	532	.62	457	.57	363	.51	222	.42						
	10 ⁵ / ₈ x 2 ⁵ / ₈	5"	623	.65	554	.60	468	.53	353	.44	186	.32						
	11 x 3 BC	6"	649	.53	567	.47	473	.42	334	.36								
	10 ⁵ / ₈ x 2 ⁵ / ₈	6"	692	.67	600	.61	491	.55	311	.45								
	11 x 3 BC	7"	723	.67	612	.60	497	.53	365	.46								
	11 x 2 ³ / ₄	6"	736	.87	650	.81	556	.73	441	.63	222	.45						
	12 x 2 ⁷ / ₈	5"	699	.88	638	.83	577	.78	508	.73	419	.65	268	.51				
	12 ¹ / ₄ x 2 ⁷ / ₈	5"	725	.99	664	.91	605	.86	541	.81	467	.76	366	.68	159	.48		
	10 ⁵ / ₈ x 2 ⁵ / ₈	7"	806	.82	704	.73	575	.65	388	.55								
	13 x 3 ¹ / ₄ BC	5"	741	1.05	684	1.01	628	.96	568	.90	501	.84	418	.77	290	.67		
	11 x 2 ³ / ₄	7"	883	1.09	790	.96	694	.83	575	.70	335	.59						
	13 x 3 ¹ / ₄	5"	822	1.28	760	1.19	700	1.09	640	1.00	576	.91	503	.81	409	.70	175	.48
	12 x 2 ⁷ / ₈	6"	892	1.08	822	.98	746	.92	650	.86	474	.73	172	.53				
	13 x 3 ¹ / ₄ BC	6"	901	1.13	836	1.07	772	1.03	703	.99	625	.95	524	.90	345	.77		
	12 ¹ / ₄ x 2 ⁷ / ₈	6"	923	1.27	852	1.20	779	1.13	699	1.04	604	.94	473	.81	196	.56		
	12 x 2 ⁷ / ₈	7"	1010	1.46	892	1.33	777	1.23	668	1.12	552	1.01	397	.87				
	12 ¹ / ₄ x 2 ⁷ / ₈	7"	1049	1.59	965	1.48	872	1.38	771	1.28	655	1.15	502	.96				
	13 x 3 ¹ / ₄	6"	1007	1.50	945	1.42	878	1.34	801	1.26	705	1.17	566	1.06	302	.81		
	13 x 3 ¹ / ₄ BC	7"	1098	1.57	1022	1.48	933	1.37	829	1.26	707	1.15	556	1.05	334	.92		
13 x 3 ¹ / ₄	7"	1185	2.01	1099	1.89	1016	1.77	929	1.64	831	1.50	709	1.36	509	1.18			
13 ¹ / ₁₆ x 3 ³ / ₁₆	5"	1247	2.28	1162	2.16	1070	2.03	970	1.87	869	1.72	768	1.57	671	1.43	542	1.22	
13 ¹ / ₁₆ x 3 ³ / ₁₆	6"	1365	2.54	1280	2.36	1195	2.18	1061	1.99	936	1.80	811	1.61	707	1.47	568	1.26	
13 ¹ / ₁₆ x 3 ³ / ₁₆	7"	1434	2.67	1342	2.48	1242	2.28	1119	2.06	989	1.87	854	1.70	724	1.53	594	1.33	
SPB-15	14 x 3 ¹ / ₄ BC	6"	1521	2.03	1383	1.86	1232	1.70	1062	1.53	872	1.36	664	1.18	443	.97	190	.70
	14 x 3 ¹ / ₄ BC	8"	1842	2.40	1654	2.15	1409	1.86	1148	1.60	907	1.39	678	1.19	436	.97		
	14 x 3 ¹ / ₄ BC	10"	1978	2.46	1684	2.15	1410	1.84	1157	1.58	903	1.36	610	1.19	136	1.01		
	15 ¹ / ₂ x 5 BC	6"	1828	3.01	1706	2.86	1583	2.71	1460	2.57	1333	2.43	1200	2.30	1054	2.16	882	1.98
	14 x 3 ¹ / ₄	6"	1928	3.53	1808	3.33	1678	3.10	1533	2.83	1366	2.54	1163	2.23	899	1.84	534	1.26
	16 ¹ / ₂ x 4 ³ / ₈ BC	6"	1951	3.43	1855	3.33	1753	3.22	1646	3.10	1531	2.97	1407	2.83	1272	2.67	1124	2.51
	14 ¹ / ₄ x 6 ¹ / ₈	6"	2022	3.95	1900	3.68	1776	3.42	1644	3.16	1499	2.90	1333	2.63	1137	2.34	902	2.00
	15 x 7	6"	2112	4.42	2007	4.20	1899	3.98	1787	3.77	1668	3.55	1540	3.33	1400	3.11	1241	2.85
	14 ³ / ₄ x 4	6"	2153	4.28	2030	4.07	1906	3.87	1778	3.67	1640	3.44	1485	3.18	1303	2.87	1079	2.48
	15 ¹ / ₂ x 5 BC	8"	2298	3.98	2173	3.72	2024	3.45	1846	3.16	1642	2.88	1422	2.61	1194	2.34	960	2.08
	15 ¹ / ₂ x 5	6"	2217	4.92	2100	4.70	1987	4.50	1873	4.31	1755	4.10	1628	3.88	1486	3.62	1322	3.30
	14 x 3 ¹ / ₄	8"	2393	4.21	2259	4.00	2087	3.73	1860	3.38	1566	2.91	1236	2.37	906	1.83	551	1.27
	14 x 3 ¹ / ₄	10"	2459	4.14	2326	3.95	2135	3.65	1863	3.20	1554	2.70	1257	2.24	942	1.81	356	1.24
	15 ¹ / ₂ x 5 BC	10"	2490	3.90	2259	3.60	2039	3.32	1828	3.06	1620	2.80	1411	2.56	1188	2.31	938	2.06
	16 ¹ / ₂ x 4 ³ / ₈ BC	8"	2510	4.36	2345	4.13	2176	3.90	2001	3.66	1819	3.44	1630	3.21	1434	2.99	1234	2.76
	16 ¹ / ₂ x 4 ³ / ₈ BC	10"	2636	4.41	2447	4.19	2250	3.96	2052	3.72	1854	3.48	1658	3.24	1459	3.00	1252	2.75
	16 ¹ / ₂ x 4 ³ / ₈	6"	2487	6.56	2371	6.26	2259	6.00	2146	5.77	2029	5.53	1906	5.29	1774	5.01	1627	4.70
	14 ³ / ₄ x 4	8"	2759	5.52	2587	5.21	2406	4.86	2212	4.49	2001	4.10	1767	3.69	1506	3.24	1207	2.73
	14 ¹ / ₄ x 6 ¹ / ₈	8"	2774	5.32	2590	5.04	2392	4.70	2173	4.30	1927	3.85	1650	3.33	1347	2.78	1027	2.22
	14 ¹ / ₄ x 6 ¹ / ₈	10"	3056	6.14	2784	5.66	2475	5.07	2179	4.45	1907	3.86	1645	3.31	1374	2.79	1057	2.28
	14 ³ / ₄ x 4	10"	3035	6.00	2786	5.45	2543	5.00	2302	4.58	2055	4.16	1798	3.73	1523	3.27	1215	2.77
	15 x 7	8"	2971	6.51	2801	6.11	2629	5.72	2451	5.33	2262	4.93	2058	4.52	1835	4.08	1584	3.60
	15 ¹ / ₂ x 5	8"	3088	7.32	2917	6.84	2739	6.37	2552	5.92	2354	5.46	2139	5.01	1904	4.53	1643	4.01
	15 x 7	10"	3271	6.98	3044	6.49	2822	6.04	2599	5.62	2371	5.17	2134	4.70	1882	4.19	1608	3.64
	15 ¹ / ₂ x 5	10"	3528	7.98	3259	7.42	2973	6.81	2693	6.20	2426	5.62	2169	5.06	1915	4.53	1653	3.99
	16 ¹ / ₂ x 4 ³ / ₈	8"	3324	8.72	3166	8.28	2996	7.81	2817	7.33	2629	6.85	2436	6.36	2235	5.89	2026	5.41
	16 ¹ / ₂ x 4 ³ / ₈	10"	3734	9.30	3553	8.93	3334	8.45	3082	7.87	2817	7.25	2555	6.64	2303	6.05	2058	5.47

Continued on page 10



SPB SERIES DIRECT DRIVE RATING TABLES at 2850 RPM (cont'd)

NOTE: THESE RATINGS ARE FOR 50 CYCLE MOTORS ONLY.

CFM and BHP at Static Pressure Shown

Ratings at 70°F., .075 Density, Sea Level

MODEL NO.	WHEEL DIA. & WIDTH	INLET SIZE	9" SP		10" SP		11" SP		12" SP		13" SP	
			CFM	BHP	CFM	BHP	CFM	BHP	CFM	BHP	CFM	BHP
SPB-12	13 ¹¹ / ₁₆ x 3 ³ / ₁₆	5"	111	.48								
	13 ¹¹ / ₁₆ x 3 ³ / ₁₆	6"	262	.72								
	13 ¹¹ / ₁₆ x 3 ³ / ₁₆	7"	274	.72								
SPB-15	14 x 3 ¹ / ₄	6"	96	.62								
	14 ¹ / ₄ x 6 ¹ / ₈	10"	501	1.64								
	15 ¹ / ₂ x 5 BC	10"	619	1.81								
	15 ¹ / ₂ x 5 BC	6"	649	1.71	255	1.16						
	14 ¹ / ₄ x 6 ¹ / ₈	6"	637	1.61	358	1.19						
	14 ¹ / ₄ x 6 ¹ / ₈	8"	686	1.68	177	1.05						
	15 ¹ / ₂ x 5 BC	8"	712	1.81	416	1.48						
	14 ³ / ₄ x 4	6"	792	1.98	430	1.40						
	14 ³ / ₄ x 4	10"	829	2.20	254	1.51						
	14 ³ / ₄ x 4	8"	854	2.10	344	1.24						
	16 ¹ / ₂ x 4 ³ / ₈ BC	10"	1027	2.50	761	2.24	355	1.88				
	16 ¹ / ₂ x 4 ³ / ₈ BC	6"	960	2.32	775	2.11	558	1.86	236	1.47		
	15 x 7	6"	1050	2.54	805	2.11	461	1.46				
	16 ¹ / ₂ x 4 ³ / ₈ BC	8"	1028	2.51	814	2.23	573	1.90	163	1.43		
	15 ¹ / ₂ x 5	6"	1124	2.92	875	2.43	574	1.89	245	1.35		
	15 x 7	10"	1293	3.05	890	2.39	281	1.66				
	15 x 7	8"	1294	3.05	944	2.40	448	1.56				
	15 ¹ / ₂ x 5	10"	1365	3.44	1009	2.82	206	1.73				
	15 ¹ / ₂ x 5	8"	1349	3.42	1010	2.74	588	1.93				
	16 ¹ / ₂ x 4 ³ / ₈	6"	1461	4.32	1268	3.85	1040	3.30	772	2.66	438	1.96
16 ¹ / ₂ x 4 ³ / ₈	10"	1811	4.88	1550	4.27	1250	3.57	817	2.64	332	1.87	
16 ¹ / ₂ x 4 ³ / ₈	8"	1803	4.91	1558	4.38	1272	3.77	884	2.95			



DANGER

All fans & blowers shown have rotating parts and pinch points. Severe personal injury can result if operated without guards. Stay away from rotating equipment unless it is disconnected from its power source.

Read operating instructions.

METRIC CONVERSION FACTORS

POWER:	1 HP = .7457 kw 1 kw = 1.34 HP	HP = Horse power kw = kilowatts
VOLUME:	1 cfm = .00047 m ³ /s	cfm = cubic feet per minute
FLOW:	1 m ³ /s = 2118.88 cfm	m ³ /s = cubic meters per second
PRESSURE:	1 in. wg = 248.36 Pa 1 Pa = .004 in. wg	in. wg = inches water gauge Pa = Pascals
DENSITY:	1 lb/ft ³ = 16.02 kg/m ³ 1 kg/m ³ = .0624 lb/ft ³	lb/ft ³ = Pounds per cubic foot kg/m ³ = kilograms per cubic meter
TEMPERATURE:	°C = (°F - 32) x .5556 °F = (°C x 1.8) + 32	C = Centigrade F = Fahrenheit
DIMENSIONAL:	1 in. = 25.40 mm 1 mm = .03937 in.	in. = inches mm = millimeters
WEIGHT:	1 lb = .4536 kgs. 1 kg = 2.205 lbs.	lb = pounds kg = kilograms

HOW TO SELECT A CINCINNATI SPB BLOWER

A word about ratings...

Cincinnati Fan offers three sizes of model SPB blower housings, 22 wheel sizes and two or three inlet sizes. By combining these different housings, wheels and inlet sizes, we offer more standard direct drive pressure blower performance ratings than any other fan company in the world. By offering so many direct drive ratings, chances are very good that we can meet your performance requirements with a compact, cost efficient, direct drive Model SPB blower instead of a heavier, larger and more expensive V-belt driven blower. **Our Cincinnati Fan Sales Engineer for your area is a ratings expert who is ready to help you select precisely the right Model SPB blower for your application.**

How to use the PB Series Direct-Drive Rating Tables

If you know the static pressure and CFM required for your blower application, you can determine which SPB blower you should consider by referring to the tables on Pages 6 and 7 of this catalog. If you will be using a 50 cycle motor, refer to the tables on pages 9 and 10. To use the tables, follow these simple directions:

1. Reading to the right, find the column heading which displays the static pressure (SP) you require.
2. Reading down that column, find the line(s) displaying the CFM rating(s) which will satisfy your requirement.
3. Follow the line(s) to the left side of the table, where you will identify the wheel(s) and the blower housing model(s) used to achieve the CFM rating(s).

You may find that several ratings come close to meeting your requirements. Generally, the rating with the lowest brake horsepower requirement (BHP) is the best selection (highest efficiency, least noise). In some situations, other requirements, such as blower dimensions and/or specific inlet/outlet sizes, may override the lower horsepower rule-of-thumb. **A Cincinnati Fan Sales Engineer is available to assist you with selection and pricing information.**

Some DOs and DON'Ts

- DO...** consider that radial blades are self-cleaning in most applications. Backward curved (BC) blades are not self-cleaning and may collect dust which can cause balance problems.
- DO...** specify heat-resistant construction (steel wheel) for use with airstreams having temperatures exceeding 200° F (93° C). BC wheels are not available in steel.

WARNING

- DO NOT** use a steel wheel and a steel blower housing in any type of environment where sparks could cause an explosion and/or fire. **See Page 5.**
- DO NOT** use any blower with an unducted inlet and/or outlet without an inlet and/or outlet guard. Severe personal injury could result. **See Page 4 for guard accessory.**

8 STANDARD DISCHARGE POSITIONS AVAILABLE. 45° DISCHARGE POSITIONS AVAILABLE AT EXTRA CHARGE.^H
Discharges shown are determined by viewing fan from motor or drive side.



CW-TH
Clockwise Top
Horizontal
Discharge



CW-DB
Clockwise
Down-Blast
Discharge



CW-BH
Clockwise
Bottom
Horizontal
Discharge



CW-UB
Clockwise
Up-Blast
Discharge



CCW-TH
Counter-
Clockwise Top
Horizontal
Discharge



CCW-DB
Counter-
Clockwise
Down-Blast
Discharge



CCW-BH
Counter-
Clockwise
Bottom
Horizontal
Discharge



CCW-UB
Counter-
Clockwise
Up-Blast
Discharge

^H Discharge flange or slide gate damper not available on some discharge positions. See page 15.



DIMENSIONS and SPECIFICATIONS

NOTE: The table below contains blower housing dimensions common to all arrangements on pages 12, 13 and 14.

MODEL	C	D	J	M	N	O	P	R	S	T	AA	DD ^④
SPB-9	1 1/2	3 3/4	3 3/8	5 5/8	9/16	6 3/4	8	8 11/32	7 1/4	7/8	5 ^①	3 15/16
SPB-12	1 1/2	4 1/4	3 5/8	7 9/32	3/8	8 1/2	10 1/4	11	9 1/4	7/8	7 ^②	5 15/16
SPB-15	1 1/4	8 3/4	5 5/8	8 11/32	1 5/8	10 3/32	11 15/16	13 3/32	10 29/32	1 1/16	8 ^③	7 15/16

① SPB-9 ALSO AVAILABLE WITH 4" O.D. INLETS.

② SPB-12 ALSO AVAILABLE WITH 5" AND 6" O.D. INLETS.

③ SPB-15 ALSO AVAILABLE WITH 6" AND 10" O.D. INLET.

④ DISCHARGE FLANGE OR SLIDE GATE DAMPER NOT AVAILABLE ON SOME DISCHARGE POSITIONS. SEE PAGE 15 FOR LIMITATIONS.



Arrangement #4, Direct Drive

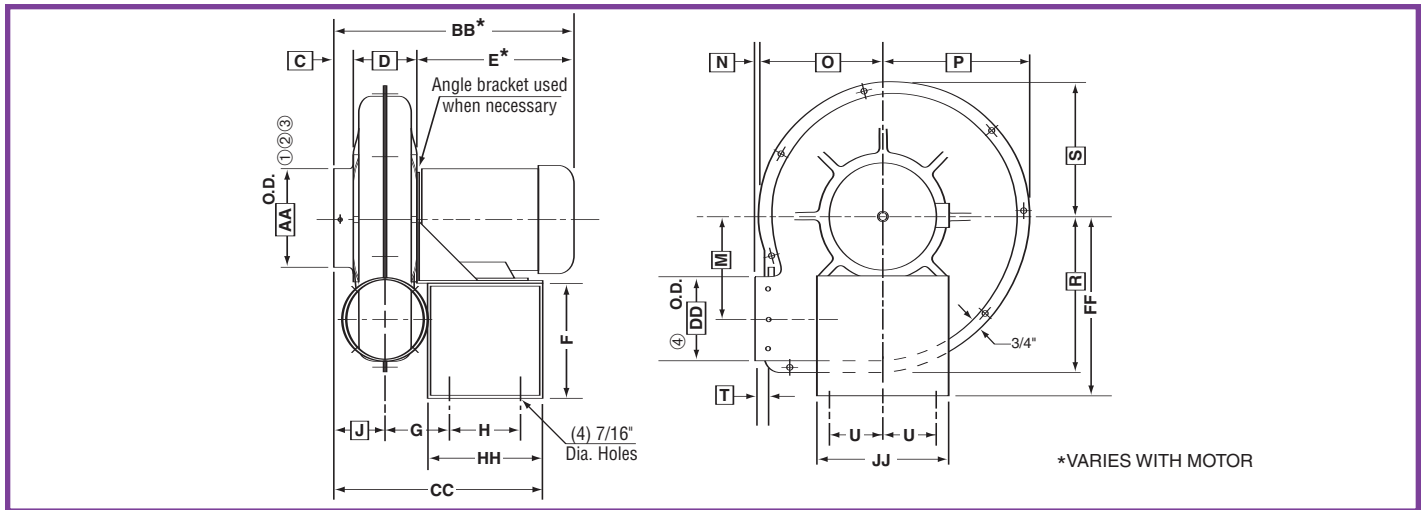

Note: For common boxed blower housing dimensions, see above.

DIMENSIONS IN INCHES ± 1/8"

DIMENSIONS SUBJECT TO CHANGE WITHOUT NOTICE.

MODEL NO.	MOTOR FRAME	E*	F	G	H	U	BB*	CC	FF	HH	JJ	KK	MM
SPB-9	56	12 1/2	6 7/8	3 3/16	5 3/4	2 3/4	17 3/4	13 3/8	10 7/16	7 7/8	7	1 13/16	3 11/16
	143-145T	12	8 1/4	4	5	3 3/4	17 1/4	13 7/8	11 7/8	8	9	1 13/16	3 11/16
SPB-12	56	12 1/2	8 1/4	3 7/8	5	3 3/4	18 1/4	14	11 7/8	8	9	1 13/16	3 15/16
	143T-145T	12	8 1/4	4 1/4	5	3 3/4	17 3/4	14 3/8	11 7/8	8	9	1 13/16	3 15/16
	182T-184T	15 1/2	6 7/16	4 5/8	8 3/4	4 15/16	21 1/4	18 1/2	11 7/8	11 3/4	12	1 13/16	3 15/16
SPB-15	182T-215T	15 1/4	9 15/16	6 7/8	8 3/4	4 15/16	25 1/4	23 3/4	15 3/16	13 3/4	15	1 9/16	5 15/16
	254T-256T	20 1/4	8 15/16	6 7/8	13	4 15/16	30 1/4	28	15 3/16	18	16 1/2	1 9/16	5 15/16

① SPB-9 ALSO AVAILABLE WITH 4" O.D. INLETS.

② SPB-12 ALSO AVAILABLE WITH 5" AND 6" O.D. INLETS.

③ SPB-15 ALSO AVAILABLE WITH 6" AND 10" O.D. INLET.

④ DISCHARGE FLANGE OR SLIDE GATE DAMPER NOT AVAILABLE ON SOME DISCHARGE POSITIONS. SEE PAGE 15 FOR LIMITATIONS.

KK & MM pertain to arrangement #4HM on page 13 only.

APPROXIMATE SHIPPING WEIGHT IN POUNDS^H

MODEL NO.	MOTOR FRAME	ARR.1 (No motor)	ARR.2 (No motor)	ARR.4	ARR.4HM	ARR.9	Nominal Motor HP - WT
SPB-9	56-145T	59	27	48	42	87	1/2 - 22
SPB-12	56-145T	66	53	77	68	107	2 - 41
	182T-215T	111		116	103	187	5 - 76
SPB-15	182T-215T	125	84	176	166	201	5 - 76
	254T-256T	170		180	212	292	10 - 122

^H ARRANGEMENT 4, 4HM and 9 WEIGHTS INCLUDE NOMINAL HP AND CORRESPONDING MOTOR WEIGHT INDICATED IN COLUMN EIGHT. MAKE CORRECTIONS AS NECESSARY BY DEDUCTING NOMINAL MOTOR WEIGHT AND ADDING WEIGHT OF ACTUAL MOTOR TO BE USED.



DIMENSIONS and SPECIFICATIONS

Arrangement #4 HM, (Horizontal Mount) Direct Drive

NOTE: Inlet flange is optional on arrangement #4HM.

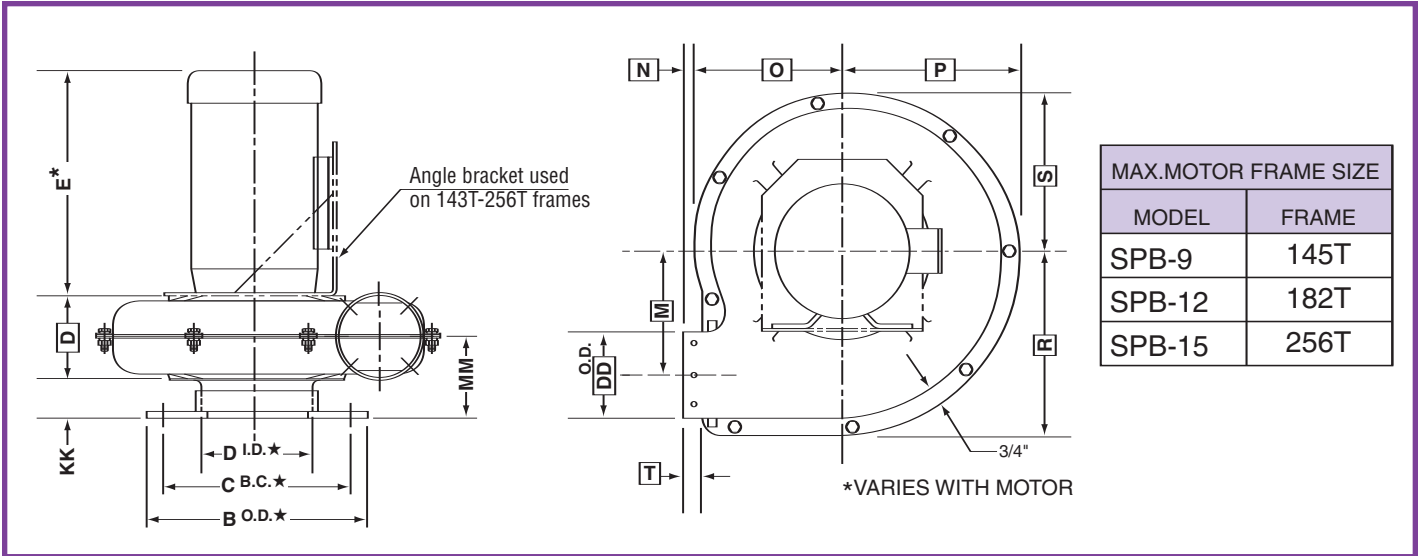

Note: For common boxed blower housing dimensions, see top of Page 12.

H For inlet flange dimensions B, C and D above, see flange dimension table on page 15 for corresponding A dimension. For KK and MM dimensions, see page 12.



Arrangement #2, Belt Drive

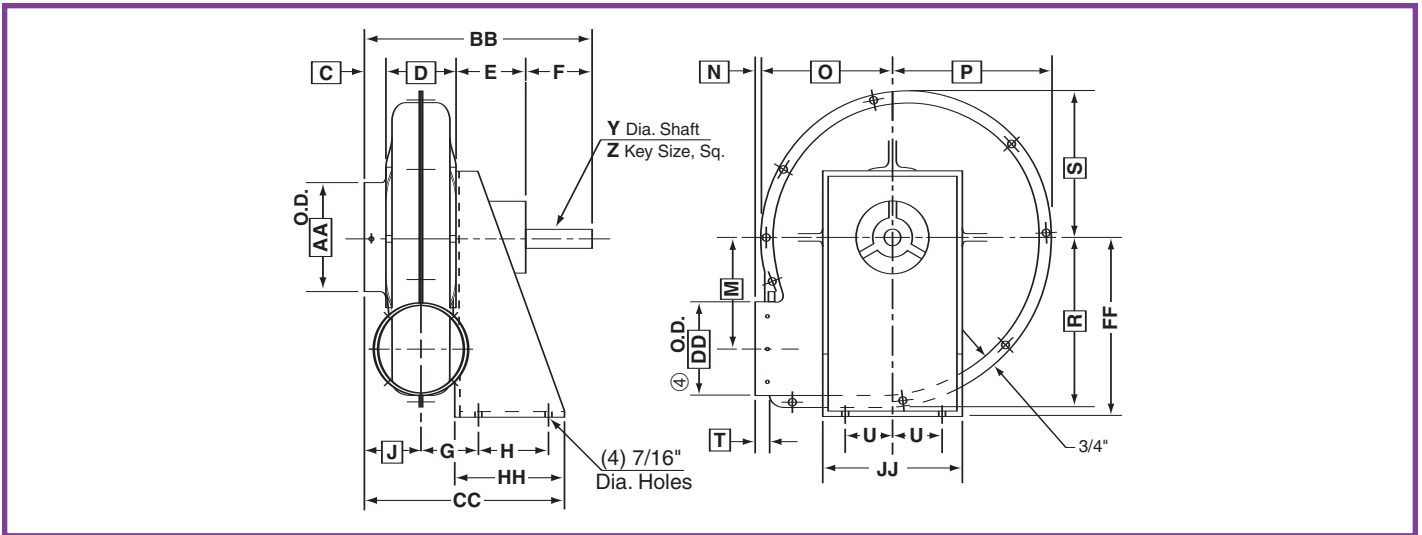

Note: For common boxed blower housing dimensions, see top of Page 12.

DIMENSIONS IN INCHES ± 1/8"

DIMENSIONS SUBJECT TO CHANGE WITHOUT NOTICE.

MODEL NO.	E	F	G	H	U	Y	Z	BB	CC	FF	HH	JJ
SPB-9	3 11/16	3	2 7/8	4 1/4	2 7/8	3/4	3/16	11 15/16	11	9 7/8	6	7 3/4
SPB-12	5 1/2	4	3 5/8	4 1/2	2 7/8	1	1/4	15 1/4	11 3/4	11 1/2	7	9
SPB-15	5 3/16	4	5 7/8	5 1/2	3 3/4	1 7/16	3/8	19 3/16	18	15	8	10 1/4

DISCHARGE FLANGE OR SLIDE GATE DAMPER NOT AVAILABLE ON SOME DISCHARGE POSITIONS. SEE PAGE 15



DIMENSIONS and SPECIFICATIONS

Arrangement #1 and #9, Belt Drive

NOTE: Arrangement 9 dimensions are the same as arrangement 1 with exception of dimensions C.D. and MML which are for arrangement 9 only.

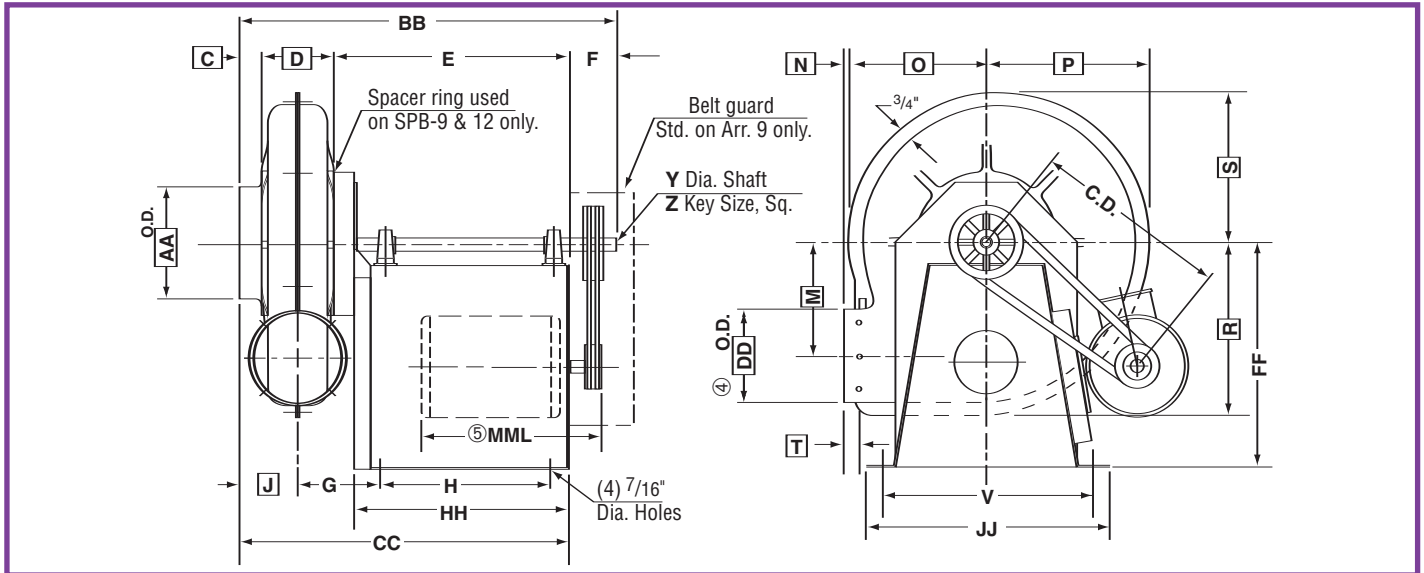

Note: For common boxed blower housing dimensions, see top of Page 12.

DIMENSIONS IN INCHES ± 1/8"

DIMENSIONS SUBJECT TO CHANGE WITHOUT NOTICE.

MODEL NO.	MOTOR FRAME	E	F	G	H	V	Y	Z	BB	CC	FF	HH	JJ	MML ^⑤
SPB-9	56-145T	16 1/4	3	5 5/8	10	11 3/8	3/4	3/16	24 1/2	21 1/2	14	15	12 7/8	15
SPB-12 ★	56-145T★	16 1/4	4	5 7/8	10	11 3/8	1	1/4	26	22	14	15	12 7/8	15
	182T-215T	19 1/4	4	5 7/8	13	16	1	1/4	29	25	18	18	17 1/2	19
SPB-15 ★	143T-215T★	18	4	6 7/8	13	16	1 7/16	3/8	32	28	18	18	17 1/2	19
	254T-256T	24 1/2	4	6 7/8	19 1/2	17 1/4	1 7/16	3/8	38 1/2	34 1/2	23	24 1/2	19	26

④ DISCHARGE FLANGE OR SLIDE GATE DAMPER NOT AVAILABLE ON SOME DISCHARGE POSITIONS. SEE PAGE 15

⑤ MML IS MAXIMUM MOTOR LENGTH ON CUSTOMER-SUPPLIED MOTOR. MOTOR MANUFACTURERS "C" DIMENSION CANNOT EXCEED MML.

★ ALL ARRANGEMENT 1 UNITS USE SMALL BASE DIMENSIONS.

C.D. BELT CENTER DISTANCE (Dimensions in Inches)

MODEL NO.	MOTOR FRAME SIZE									
	56		143T-145T		182T-184T		213T-215T		254T-256T	
	MIN.	MAX.	MIN.	MAX.	MIN.	MAX.	MIN.	MAX.	MIN.	MAX.
SPB-9	9 1/2	11 1/2	9 1/2	11 1/2						
SPB-12	9 1/2	11 1/2	9 1/2	11 1/2	13 1/4	15	13 1/4	15		
SPB-15			12 1/4	13 3/8	13 5/8	15 1/8	14 3/8	16	16 3/4	18 7/8

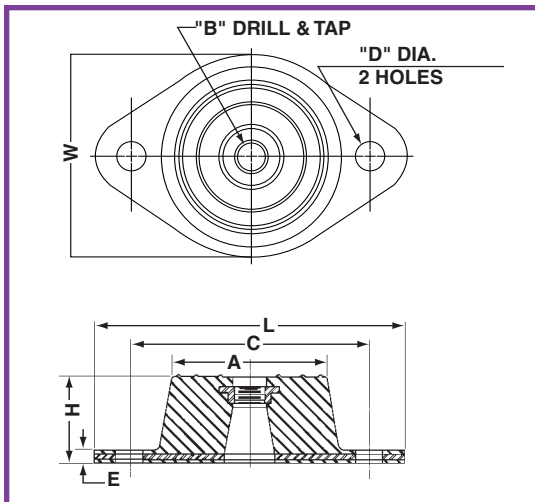

RUBBER-IN-SHEAR (RIS) VIBRATION ISOLATORS

TYPE R NEOPRENE IN SHEAR MOUNTINGS												
TYPE	MAX. LOAD EACH LBS.	DEFLECTION IN INCHES	DIMENSION IN INCHES									
			R	L	W	H	A	B	C	D	E	
R1	BLUE	35	0.20	3 1/8	1 3/4	1	1 1/4	9/16 - 16NC	5/16 - 18NC	2 3/8	1 1/32	3/16
	BLACK	45										
	RED	70										
	GREEN	120										
R2	BLUE	135	0.25	3 7/8	2 3/8	1 1/4	1 3/4	9/16 - 16NC	5/16 - 18NC	3	1 1/32	7/32
	BLACK	170										
	RED	240										



DIMENSIONS and SPECIFICATIONS

INLET AND DISCHARGE FLANGE DIMENSIONS FOR SPB-9 THROUGH SPB-15 ©

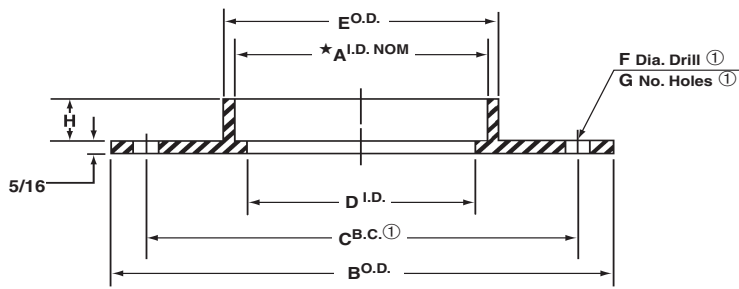

Dimensions in inches

A★	B*	C*	D	E	F	G	H
4 ¹ / ₁₆	9	7 ¹ / ₂	3 ¹¹ / ₁₆	4 ⁹ / ₁₆	7 ⁷ / ₁₆	4	1 ¹⁵ / ₁₆
5 ¹ / ₁₆	11	8 ¹ / ₂	4 ⁹ / ₁₆	5 ⁹ / ₁₆	7 ⁷ / ₁₆	4	1 ¹⁵ / ₁₆
6 ¹ / ₁₆	11	9 ¹ / ₂	5 ¹ / ₂	6 ⁹ / ₁₆	7 ⁷ / ₁₆	4	1 ¹ / ₁₆
7 ¹ / ₁₆	11	9	6 ⁷ / ₁₆	7 ⁵ / ₈	7 ⁷ / ₁₆	8	1 ¹⁵ / ₁₆
8 ¹ / ₁₆	13 ¹ / ₂	11 ³ / ₄	7 ¹ / ₂	8 ⁵ / ₈	7 ⁷ / ₁₆	8	1
10 ¹ / ₁₆	16	14 ¹ / ₄	9 ¹¹ / ₁₆	10 ⁹ / ₁₆	7 ⁷ / ₁₆	8	1

⊃ Holes will not be drilled unless customer specifies. If drilled per our standard, holes will be drilled on centerlines unless specified otherwise on order. Dimensions "C, F & G" can be made to customer specifications; at an additional charge.

⊃ All dimensions are ±1/8" except C & F.

⊃ All flanges are 319 cast aluminum except SPB-15 inlet flange is 10 gauge steel.

★ "A" fits over inlet or outlet of blower, "AA" or "DD" dimension.

* Meet ANSI-125 pound flange dimensions.

© DISCHARGE FLANGES NOT AVAILABLE ON DOWNBLAST OR BOTTOM ANGULAR DOWN DISCHARGE POSITIONS.

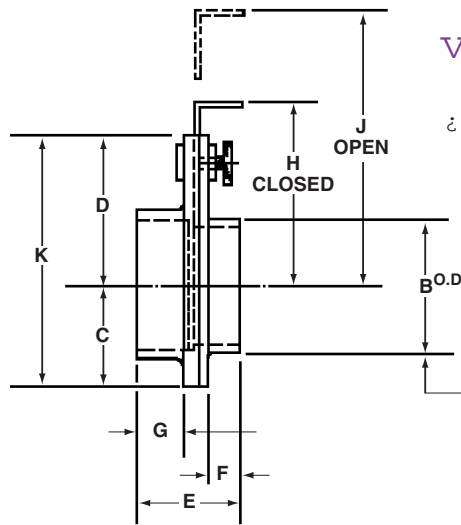
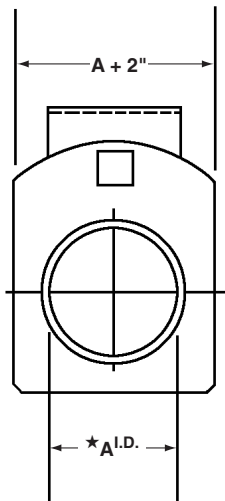

∇ NOT AVAILABLE ON DOWNBLAST OR BOTTOM ANGULAR DOWN DISCHARGE POSITIONS.

⊃ Gate halves are 319 cast aluminum.
Slide gate is 12 gauge galvanized steel.
Aluminum slide gate available at additional charge.

Flange, filter or guard can be mounted over this O.D.

DIMENSIONS IN INCHES

MODEL	A★	B	C	D	E	F	G	H	J	K
FG-4	4 ¹ / ₁₆	3 ¹⁵ / ₁₆	3 ¹ / ₄	4 ¹ / ₂	2 ¹¹ / ₁₆	1	1 ¹ / ₁₆	5 ⁵ / ₈	9	7 ³ / ₄
FG-5	5 ¹ / ₁₆	4 ¹⁵ / ₁₆	3 ¹ / ₂	5 ¹ / ₂	2 ⁹ / ₁₆	1 ¹ / ₈	7 ⁷ / ₈	6 ¹ / ₈	10 ¹ / ₂	9
FG-6	6 ¹ / ₁₆	5 ¹⁵ / ₁₆	4	5 ¹ / ₂	2 ¹¹ / ₁₆	1 ¹ / ₁₆	1	6 ¹ / ₄	11 ¹ / ₂	9 ¹ / ₂
FG-7	7 ¹ / ₁₆	6 ¹⁵ / ₁₆	4 ¹ / ₂	5 ¹ / ₂	2 ⁷ / ₈	1 ¹ / ₈	1 ¹ / ₈	6 ¹ / ₄	12 ¹ / ₂	10
FG-8	8 ¹ / ₁₆	7 ¹⁵ / ₁₆	5	6 ³ / ₄	2 ¹³ / ₁₆	1	1 ³ / ₁₆	7 ³ / ₄	15	11 ³ / ₄
FG-10	10 ¹ / ₁₆	9 ¹⁵ / ₁₆	6	8	3 ¹ / ₁₆	1 ⁵ / ₁₆	1	9	18 ¹ / ₂	14

★ "A" FITS OVER INLET OR OUTLET OF BLOWER, "AA" OR "DD" DIMENSION

DIMENSIONS SUBJECT TO CHANGE WITHOUT NOTICE.