

LC, L2 & L3 Sidewall Propeller Fans

Belt Drive - Exhaust & Supply

Catalog L01-July 2007

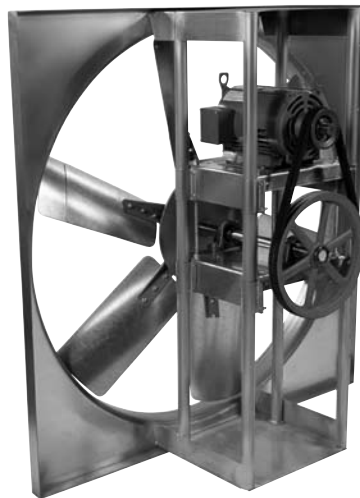
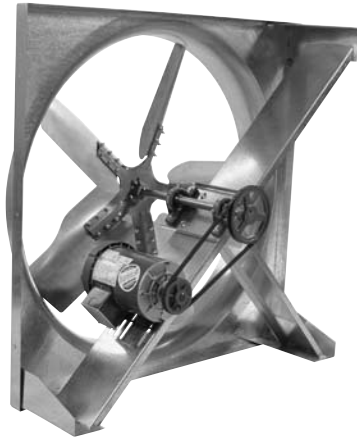

The World's Leading Producer of
Air Movement Products



Soler & Palau USA, Div. of Soler & Palau Ventilation Group, certifies that the models shown herein are licensed to bear the AMCA Seal. The ratings shown are based on test and procedures performed in accordance with AMCA Publication 211 and AMCA Publication 311 and comply with the requirement of the AMCA Certified Ratings Program.

Soler&Palau  Ventilation Group

COMMERCIAL PRODUCT LINE



Model LC - Construction Level I

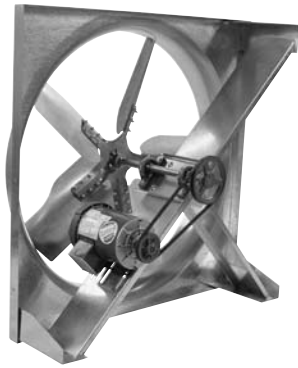

Application

Model LCE (exhaust) and LCS (supply) are high capacity belt driven propeller fans rated from 3,000 to 40,000 cfm to .625" w.g. static pressure. Their primary application is the exhaust or supply of large volumes of air at relatively low static pressures from commercial, light industrial and agricultural buildings such as manufacturing and assembly plants, warehouses, parking garages, gymnasiums, equipment rooms, distribution centers, poultry and greenhouses.

Wall mounting provides an easy, economical installation. Belt driven fans provide large volumes of air at low fan speeds and low noise levels and afford quick, easy performance adjustments. All necessary accessories are available to meet any need or specification.

When suspended from the ceiling, thus keeping floor spaces open, model LC can be installed to direct large volumes of air downward toward work centers improving employee comfort and productivity.

When mounted in portable housings with OSHA guards, Model LC-P can be used as a mancooler and rolled to hot spots to provide needed employee relief from heat or fumes and help increase productivity.

Also see Model L with construction levels 2 and 3 for higher static pressure performances and heavier construction designs. (Pages 3 and 4.)

Construction/Specification Checklist

Belt Drive, Wall Exhaust (or Supply) Propeller Fan shall be provided as follows:

CERTIFICATIONS: Fans shall be AMCA Licensed for air and sound performance. Fans shall be UL and CUL 705 listed for electrical safety and reliability (Optional).

PANEL ASSEMBLY: Panels shall be heavy-gauge G90 galvanized (optional aluminum) with spun one piece venturi. Motor and bearing plate shall be a minimum of 12 gauge galvanized steel except size 20. Panel end support frame assembly shall be of welded, not bolted, construction with prepunched mounting holes for easy installation.

PROPELLER: Blades shall be die formed galvanized G90 steel of minimum 16 gauge. Blades shall be bolted to an epoxy coated hub which is keyed to the fan shaft. Propeller assembly shall be statically balanced.

DRIVES: All sheaves shall be sized to a minimum 150% of driven horsepower, machined cast iron adjustable pitch through 3 horsepower, keyed to both the motor and fan shaft. Fan shaft shall be precision turned, ground and polished steel. Belts shall be nonstatic oil and heat resistant V-belts.

BEARINGS: All bearings shall be self-aligning cast iron pillow block type with relube fitting and of the air handling design. Bearing design shall be for a minimum of L-50 200,000 hour average life.

MOTORS: Permanently sealed ball bearing type furnished to the specified voltage, phase and enclosure. All motors shall be mounted and factory run tested.

Motor Service Factor

Motor service factors are utilized in some performance selections shown. This is a safe and common industry practice that provides more performance for the investment. BHP is shown at the maximum catalog performance point. BHP at all other static pressures listed is less than that shown, in most cases substantially less. Because the motors are in the air stream there are no negative effects on motor life. 2 speed motor applications are recommended at or below their nominal BHP levels. If desired, pick the next higher horsepower to eliminate this service factor usage. Refer to the Optimizer Fan Selection Program for actual BHP at any performance point.

Optimizer Selection Program

Please refer to Soler & Palau's Optimizer Program for fan curve, submittal information and other details of this series and other Soler & Palau products. Contact your representative or factory for a copy. Visit Soler & Palau's website for additional information: www.solerpalaucanada.com.

Quickship Program

Most models and many optional accessories are available on the Quickship Program. This provides rapid delivery of standard products so that tight project deadlines can be met and downtime on replacement work can be held to a minimum. Delivery options includes next day, 3 day and 10 day shipment. See the Quickship Catalog for details.

MODEL LC - Level I Construction

Fan Size	Material (Ga. or inches)					Shaft Diameter (in.)	Max Motor Frame Size	Avg. Weight (lbs.)
	Fan Panel	Drive Frame	Motor & Bearing Supports	Propeller				
				Spider Steel	Blade Steel			
20	18	16	16	14	18	3/4	56H	85
24	16	12	12	10	16	1	145T	90
30	16	12	12	10	16	1	145T	100
36	16	12	12	7	16	1	145T	105
42	16	12	12	7	14	1	145T	110
48	16	12	12	7	14	1	145T	125
54	14	12	12	1/4	12	1 3/16	182T	240
60	14	12	12	1/4	12	1 3/16	182T	285

Optional Accessories

- Wall Housing
- Wall Collar
- Dampers
- Mounting Flanges
- Motorside Guard
- Frontside Guard
- Rainhood
- Damper Guard
- Paint Finishes
- Electrical Accessories



Standard 705 (Optional)

All specifications are subject to change without notice unless approved in submittal by Soler & Palau.

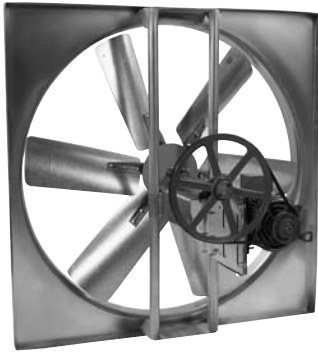

Applications:

Models LE (exhaust) and LS (supply) are high capacity wall mounted belt driven propeller fans rated from 5000 to 47,000 CFM and to 1.0" w.g. static pressure. Their primary application is the exhaust of large volumes of ventilation air from commercial and light industrial buildings such as manufacturing and assembly plants, warehouses, parking garages, gymnasiums, equipment rooms, distribution centers and OEM applications.

Wall mounting provides an easy and economical installation. All necessary accessories are available. Belt driven fans provide large volumes of air at low fan speed and low noise levels and afford quick, easy performance adjustments.

See Model L - Construction level 3 for higher static pressures and heavier construction designs or models LC for your lighter duty ventilation requirements (see pages 2 and 4).

Construction/Specification Checklist

Belt Drive, Wall Exhaust (or Supply) Propeller Fan shall be provided as follows:

CERTIFICATIONS: Fans shall be AMCA Licensed for air and sound performance. Fans shall be UL and cUL 705 listed for electrical safety and reliability (Optional).

PANEL ASSEMBLY: Panels shall be heavy-gauge G90 galvanized (optional aluminum) with spun one piece venturi. Motor and bearing plate shall be a minimum of 10 gauge G90 galvanized steel. Panel end support frame assembly shall be of welded, not bolted, construction with pre-punched mounting holes for easy installation.

PROPELLER: Propellers shall be six-bladed, die-formed, minimum 16 gauge, G90 galvanized steel bolted to a welded, structural steel hub plate and keyed to the fan shaft. Blades shall incorporate multiple laminations for 3 horsepower motors and larger. Propeller assembly shall be statically balanced.

MODEL L2 - Level 2 Construction

Fan Size	Material (Ga. or inches th.)							Max Shaft Diameter (in.)	Max Motor Frame Size	Avg. Weight (lbs.)
	Fan Panel	Drive Frame	Motor & Bearing Supports		Propeller					
			Galv	Alum	Spider	Blade				
						Steel	Steel			
24	18	10	10	1/4	1/4	16	.080	1	182T	180
30	16	10	10	1/4	1/4	16	.080	1	182T	180
36	16	10	10	1/4	1/4	16	.080	1 3/16	184T	215
42	16	10	10	1/4	3/8	16	.080	1 3/16	184T	235
48	16	10	10	1/4	3/8	16	.080	1 3/16	184T	300
54	14	10	10	1/4	3/8	16	.080	1 3/16	184T	400
60	14	10	10	1/4	3/8	16	.080	1 3/16	184T	490

DRIVES: All sheaves shall be sized to a minimum 150% of driven horsepower, machined cast iron adjustable pitch (through 3HP), keyed to both the motor and fan shaft. Fan shaft shall be precision turned, ground and polished steel. Belts shall be nonstatic oil and heat resistant V-belts.

BEARINGS: All bearings shall be self-aligning cast iron pillow block type with relube fitting and of the air handling design. Bearing design shall be for a minimum of L-50 200,000 hour average life.

MOTORS: Permanently sealed ball bearing type furnished to the specified voltage, phase and enclosure. All motors shall be mounted and factory run tested.

Motor Service Factor

Motor service factors are utilized in some performance selections shown. This is a safe and common industry practice that provides more performance for the investment. BHP is shown at the maximum catalog performance point. BHP at all other static pressures listed is less than that shown, in most cases substantially less. Because the motors are in the air stream there are no negative effects on motor life. Explosion proof and 2 speed motor applications are recommended at or below their nominal BHP levels. If desired, pick the next higher horsepower to eliminate this service factor usage. Refer to the Optimizer Fan Selection Program for actual BHP at any performance point.

Quickship Program

Most models and many optional accessories are available on the Quickship Program. This provides rapid delivery of standard products so that tight project deadlines can be met and downtime on replacement work can be held to a minimum. Delivery options includes: 2, 5 and 10 day shipments.

Optimizer Fan Selection Program

Please refer to Soler & Palau Optimizer Program for fan curve, submittal information and other details of this series and other Soler & Palau products. Contact your representative or factory for a copy. Log onto Soler & Palau's web site for additional information at: www.solerpalaucanada.com.

Optional Accessories

- Wall Housing
- Wall Collar
- Dampers
- Mounting Flanges
- Motorside Guard
- Frontside Guard
- Rainhood
- Damper Guard
- Paint Finishes
- Electrical Accessories



Standard 705
(Optional)

All specifications are subject to change without notice unless approved in submittal by Soler & Palau.



Model L3 - Construction Level 3

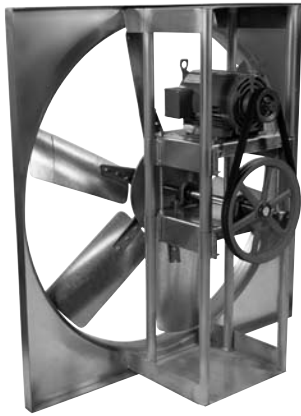

Applications:

Models LE (exhaust) and LS (supply) are high capacity wall mounted belt driven propeller fans rated from 35,000 to 85,000 and to 1.0" w.g. static pressure. Their primary application is the exhaust of large volumes of air at relatively moderate static pressure from commercial, industrial and agricultural buildings such as manufacturing and assembly plants, warehouses, foundries, mills, boiler rooms and equipment rooms.

Wall mounting provides an easy and economical installation. Belt driven fans provide large volumes of air at low fan speed and low noise levels and afford quick, easy performance adjustments. All required accessories are available with Model L.

See Models LC and L - level 2 construction, for lower static pressures and lighter duty requirements which are generally more economical. (Pages 2 and 3)

Construction/Specification Checklist

Belt Drive, Wall Exhaust (or Supply) Propeller Fan shall be provided as follows:

CERTIFICATIONS: Fans shall be AMCA Licensed for air and sound performance. Fans shall be UL and CUL 705 listed for electrical safety and reliability (optional).

PANEL ASSEMBLY: Panels shall be heavy-gauge G-90 galvanized (optional aluminum) with spun one piece venturi. Motor and bearing plate shall be a minimum of 10 gauge G90 galvanized steel structurally secured to minimum 1.25 inch schedule 40 galvanized steel pipe by means of 12 gauge galvanized steel pipe brackets. Panel end support frame assembly shall be of welded, not bolted, construction with pre-punched mounting holes for easy installation.

PROPELLER: Propellers shall be six-bladed, die-formed, minimum 16 gauge, G90 galvanized steel with double 16 gauge laminations bolted to a welded, structural steel hub plate and keyed to the fan shaft. Fan shaft shall be precision turned, ground and polished steel. Props shall be statically balanced.

MODEL L3 - Level 3 Construction

Fan Size	Material (Ga. or inches th.)						Max Shaft Diameter (in.)	Max Motor Frame Size	Avg. Weight (lbs.)
	Fan Panel	Drive Frame	Motor & Bearing Supports	Propeller					
				Spider	Blade				
					Steel	Steel			
42	16	10	10	3/8	16	0.080	1 7/16	213T	260
48	16	10	10	3/8	16	0.080	1 7/16	215T	330
54	14	10	10	3/8	16	0.080	2 3/16	256T	500
60	14	10	10	3/8	16	0.080	2 3/16	256T	530
72	12	10	10	3/8	16	0.080	2 3/16	256T	600

DRIVES: All sheaves shall be sized to a minimum 150% of drive horsepower, machined cast iron adjustable pitch through 3 horsepower, keyed to both the motor and fan shaft. Fan shaft shall be precision turned, ground and polished steel. Belts shall be nonstatic oil and heat resistant V-belts.

BEARINGS: All bearing shall be self-aligning cast iron pillow block type with relube fitting and of the air handling style. Bearing design shall be for a minimum of L-50 200,000 hour average life.

MOTORS: Permanently sealed ball bearing type furnished to the specified voltage, phase and enclosure. All motors shall be mounted and factory run tested.

Motor Service Factor

Motor service factors are used in some performance selections shown. This is a safe and common industry practice that provides more performance for the investment. BHP is at the maximum catalog performance point. BHP at all other static pressures listed is less than that shown, in most cases substantially less. Because the motors are in the air stream there are no negative effects on motor life. Explosion proof and 2 speed motor applications are recommended at or below their nominal BHP levels. If desired, pick the next higher horsepower to eliminate this service factor usage. Refer to the Optimizer Fan Selection Program for actual BHP at any performance point.

Quickship Program

Most models and many optional accessories are available on the Quickship Program. This provides rapid delivery of standard products so that tight project deadlines can be met and downtime on replacement work can be held to a minimum. Delivery options may include: 5 and 10 day shipments.

Optimizer Fan Selection Program

Please refer to Soler & Palau Optimizer Program for fan curve, submittal information and other details of this series and other Soler & Palau products. Contact you representative or factory for a copy. Log onto Soler & Palau's web site for additional information at: www.solerpalaucanada.com.

Optional Accessories

- Wall Housing
- Wall Collar
- Dampers
- Mounting Flanges
- Motorside Guard
- Frontside Guard
- Rainhood
- Damper Guard
- Paint Finishes
- Electrical Accessories



Standard 705 (Optional)

All specifications are subject to change without notice unless approved in submittal by Soler & Palau.

Model LC Sidewall Propeller Fan Level I Construction

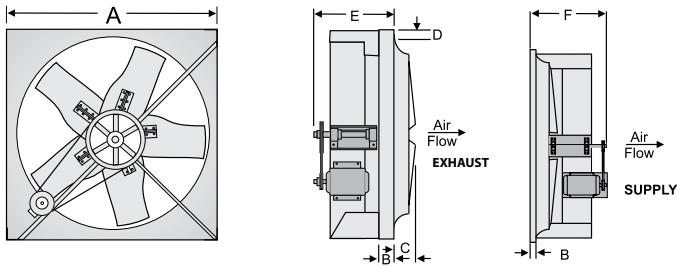

Fan Size	A Sq	B	C	D	E	F	Damper O.D. Sq Flange
20	24	2	5	1 1/4	15	23	22 1/2
24	30	2	7 1/2	1 1/4	15	23	28 1/2
30	36	2	7 1/2	1 1/4	15	24	34 1/2
36	42	2	7 1/2	1 1/4	15	24	40 1/2
42	48	2	7 1/2	1 1/4	16	24	46 1/2
48	54	2	7 1/2	1 1/4	16	24	52 1/2
54	60	2	7 1/2	1 1/4	20	26	58 1/2
60	66	2	7 1/2	1 1/4	20	26	64 1/2

Dimensions shown in inches.

Model L2 Sidewall Propeller Fan Level 2 Construction

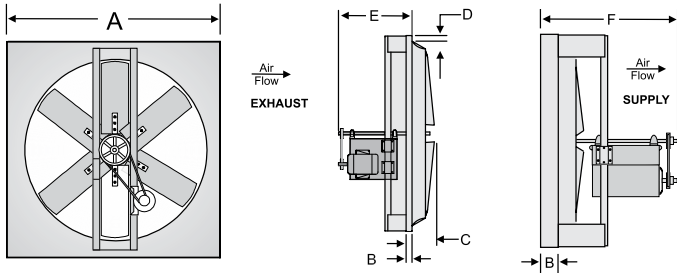

Fan Size	A Sq	B	C	D	E	F	Damper O.D. Sq Flange
24	30	2	7 1/2	1 1/4	22	26	28 1/2
30	36	2	7 1/2	1 1/4	22	26	34 1/2
36	42	2	7 1/2	1 1/4	22	26	40 1/2
42	48	2	7 1/2	1 1/4	22	26	46 1/2
48	54	2	7 1/2	1 1/4	22	26	52 1/2
54	60	2	7 1/2	1 1/4	22	26	58 1/2
60	66	2	7 1/2	1 1/4	24	28	64 1/2

Dimensions shown in inches.

Model L3 Sidewall Propeller Fan Level 3 Construction

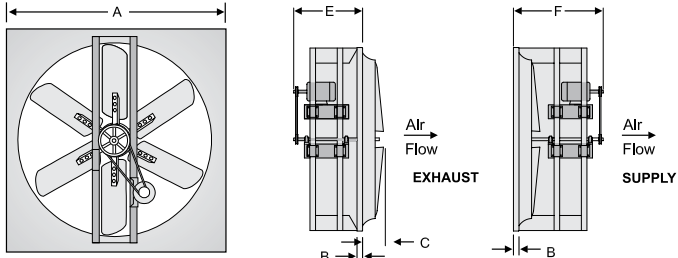

Fan Size	A Sq	B	C	D	E	F	Damper O.D. Sq Flange
42	48	2	7 1/2	1 1/4	24	28	46 1/2
48	54	2	7 1/2	1 1/4	24	28	52 1/2
54	60	2	7 1/2	1 1/4	24	28	58 1/2
60	66	2	7 1/2	1 1/4	24	28	64 1/2
72	80	2	8	1 1/4	24	28	78 1/2

Dimensions shown in inches.

SOLER & PALAU USA LIMITED WARRANTY

Soler & Palau USA (manufacturer), 6393 Powers Avenue, Jacksonville, Florida 32217, warrants equipment of its manufacture to be free from defects in design, materials and workmanship (exclusive of abrasion, corrosion or erosion) for one (1) year from the date of shipment to the original purchaser or the date of notification of readiness to ship. Motor warranty is one (1) year. In order to claim the benefit of this warranty, buyer must notify manufacturer in writing of the claimed defect within ten (10) days after discovering it and return this equipment or parts to the factory with transportation prepaid. In the event of on-site repair, no service technician will be dispatched until manufacturer receives your written purchase order. If any of the following conditions exist, the warranty will be null and void: **(1)** Buyer has permitted other persons not approved or authorized by manufacturer to alter, adjust, replace or repair the equipment or any part thereof. **(2)** Buyer has not followed instructions or other directions given in the contract documents or our maintenance manual. **(3)** When breakage or other loss or damage is the result of any negligence, misuse or fault on the part of any operator or other person not under our supervision or control. **(4)** The defect is the result of designs or drawings made, furnished or specified by others. **(5)** In the case of goods not manufactured but supplied by the manufacturer as part of a contract, manufacturer shall only be liable to the same extent that our supplier is to manufacturer, not to exceed any liability manufacturer would have for warranty on our own equipment. **(6)** Buyer has not paid in full any invoices submitted to buyer which are due for payment. **(7)** Unusual wear and tear of the equipment. Statements relating to the product, its use or installation made prior to the execution of the agreement, are not warranties except to the extent that the contrary is expressly set forth herein. It is understood that such statements were not intended to, and did not, form a part of the agreement; they were merely made in the course of negotiations of the parties. **THIS WARRANTY IS IN LIEU OF ANY OTHER EXPRESS OR IMPLIED WARRANTIES, INCLUDING ANY IMPLIED WARRANTY OF MERCHANTABILITY OR FITNESS FOR ANY PARTICULAR PURPOSE. OUR SOLE AND EXCLUSIVE OBLIGATION UNDER THIS WARRANTY IS TO REPAIR OR REPLACE DEFECTIVE EQUIPMENT OR PARTS OR, AT OUR OPTION, TO PAY THE REASONABLE COST OF REPAIR OR REPLACEMENT. BUYER AGREES THAT NO OTHER REMEDY (INCLUDING, BUT NOT LIMITED TO, INCIDENTAL OR CONSEQUENTIAL DAMAGES, DAMAGES FOR LOST PROFITS OR SALES, OR DAMAGES FOR INJURIES TO PERSON OR PROPERTY) SHALL BE AVAILABLE. NOTWITHSTANDING THE ABOVE, THE TOTAL AMOUNT THAT MAY IN ANY EVENT BE PAYABLE IN SETTLEMENT OF LIABILITY, HOWEVER INCURRED, SHALL NOT EXCEED THE CONTRACT PRICE.**



Pressure Loss Guide for Accessories

Use the estimated pressure drop graphs to help select the proper exhaust or supply fan package that will deliver the desired airflow. Enter the graph from the bottom at the specified CFM and move vertically upward to the fan curve for the desired fan size, then horizontally to the left and read the estimated static pressure drop resulting from these typical accessory packages. Add the accessory pressure loss to the system (or building) design static pressure loss to obtain the total static pressure loss to be used for the proper fan selection.

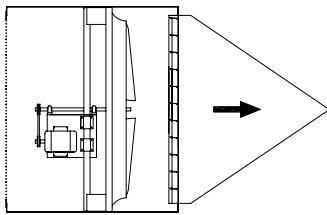

Exhaust Airflow
with Wall Housing
Gravity Damper
Rainhood
Motorside Guard

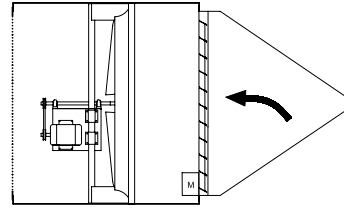

Supply Airflow
with Wall Housing
Gravity Damper
Rainhood
Motorside Guard

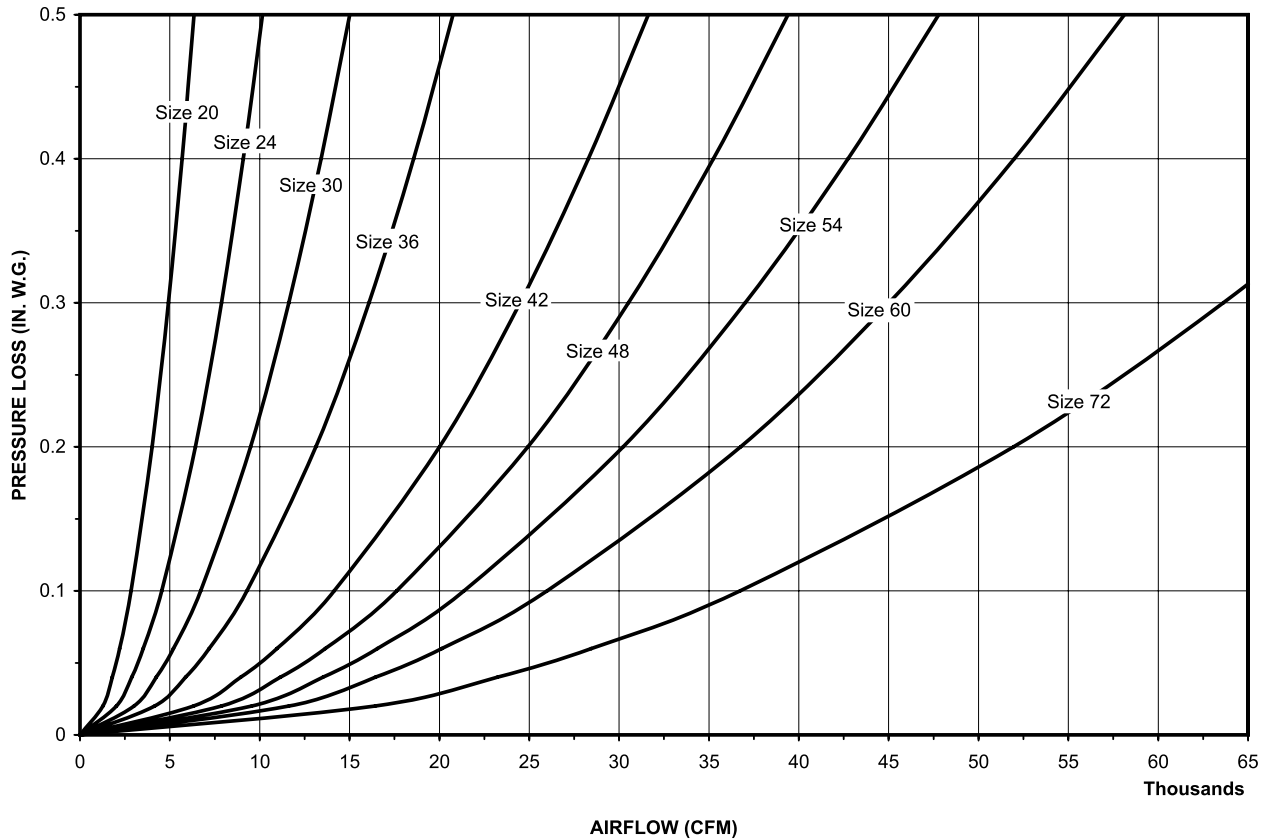

Standard Mounting Arrangements

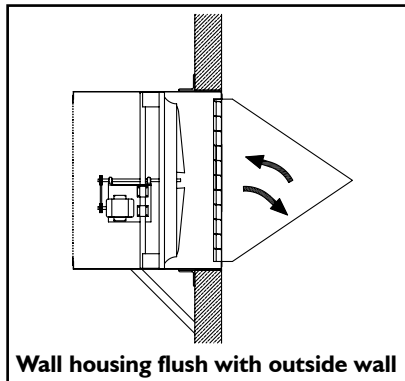

Wall housing flush with outside wall

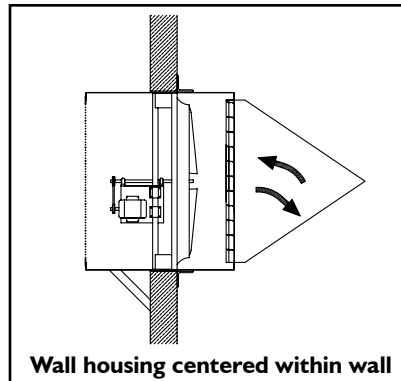

Wall housing centered within wall

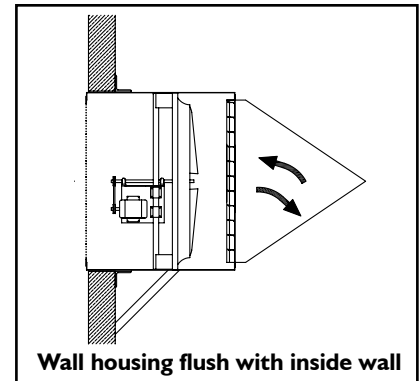

Wall housing flush with inside wall

NOTE: Supply applications have the fan venturi spun on the opposite side of the fans shown above. The fans shown are exhaust. Rainhoods are required on supply applications and recommended on exhaust applications where additional weather protection is desired. Exhaust and/or supply fans installed as shown should be serviced from the interior of the building. Where service is required from the exterior of the building, consult the factory or representative for recommendations. All bracing shown is field provided. Field flashing and caulking of wall housing seams and unused mounting holes, will ensure a weather resistant installation.

Model LC Size 20

Limits			Panel OD Square	Min. Wall Opening	Damper OD	Approx. Wt
Model	RPM	Motor Frame				
LC	1350	56H	24	25 1/2	22 1/2	85

	Size	Motor HP	Max BHP	Fan RPM	Sones (0.00" SP)	Static Pressure (Inches W.G)								
						.000	.100	.125	.150	.200	.250	.300	.375	.500
Level I Construction	Model LC 20	1/4	0.25	905	10.5	3774	3364	3247	3113	-	-	-	-	-
			0.27	920	10.8	3837	3435	3321	3193	2829	-	-	-	-
			0.28	930	11.0	3879	3482	3370	3246	2900	-	-	-	-
			0.29	945	11.3	3941	3553	3442	3324	3002	-	-	-	-
			0.30	955	11.5	3983	3600	3491	3375	3067	-	-	-	-
		1/3	0.33	990	12.2	4129	3762	3658	3550	3283	-	-	-	-
			0.34	1000	12.5	4171	3809	3706	3599	3341	-	-	-	-
			0.36	1015	12.8	4233	3878	3776	3673	3428	-	-	-	-
			0.38	1030	13.1	4296	3947	3847	3746	3512	3173	-	-	-
			0.40	1050	13.5	4379	4038	3941	3842	3621	3312	-	-	-
		1/2	0.47	1110	14.8	4629	4311	4221	4128	3933	3689	-	-	-
			0.50	1125	15.1	4692	4378	4291	4199	4009	3776	3452	-	-
			0.55	1145	15.5	4775	4468	4383	4293	4108	3890	3593	2783	-
			0.57	1160	15.9	4838	4536	4451	4364	4182	3973	3694	2959	-
			0.60	1180	16.4	4921	4625	4543	4457	4280	4081	3822	3182	-
		3/4	0.70	1260	18.3	5255	4981	4905	4827	4664	4493	4293	3875	-
			0.75	1295	19.1	5401	5135	5062	4987	4829	4666	4484	4117	-
			0.79	1320	19.7	5505	5245	5174	5101	4947	4788	4616	4278	-
			0.82	1335	20	5568	5311	5241	5169	5018	4861	4693	4371	-
			0.90	1350	20	5630	5377	5308	5237	5088	4934	4770	4462	3538

Performance ratings do not include the effects of appurtenances (accessories).

Power ratings (BHP) do not include transmission losses.

Performance certified is for installation type A-free inlet, free outlet.

The sound ratings shown are loudness values in fan sones @ 5' (1.5m) in a hemispherical free field calculated per AMCA Standard 301.

Values shown are for installation Type A-Free inlet fan sone levels.

Due to air stream cooling, the motor loading into the service factor shown does not overheat the motor and is within NEMA recommended limits. BHP at most static pressure points is less than the maximum power shown - in many cases substantially less. Use Optimizer to see the exact BHP for your selection.



Soler & Palau USA, Div. of Soler & Palau Ventilation Group, certifies that the models shown herein are licensed to bear the AMCA Seal. The ratings shown are based on test and procedures performed in accordance with AMCA Publication 211 and AMCA Publication 311 and comply with the requirement of the AMCA Certified Ratings Program.



Standard 705
(Optional)



Model LC and Model L2 Size 24



Soler & Palau USA, Div. of Soler & Palau Ventilation Group, certifies that the models shown herein are licensed to bear the AMCA Seal. The ratings shown are based on test and procedures performed in accordance with AMCA Publication 211 and AMCA Publication 311 and comply with the requirement of the AMCA Certified Ratings Program.



Limits			Panel OD Square	Min. Wall Opening	Damper OD	Approx. Wt
Model	RPM	Motor Frame				
LC	1100	145T	30	31 1/2	28 1/2	90
L2	1145	145T	30	31 1/2	28 1/2	120

Size	Motor HP	Max BHP	Fan RPM	Sones (0.00" SP)	Static Pressure (Inches W.G)											
					.000	.100	.125	.150	.200	.250	.300	.375	.500	.625		
Level 1 Construction	Model LC 24	1/4	0.25	555	9.0	4931	4168	3905	3574	2256	-	-	-	-	-	
			0.27	570	9.4	5065	4332	4085	3787	2460	-	-	-	-	-	
			0.30	600	10.2	5331	4652	4431	4180	3501	2269	-	-	-	-	
		1/3	0.33	625	10.9	5553	4912	4709	4482	3891	-	-	-	-	-	
			0.36	645	11.6	5731	5117	4926	4715	4187	-	-	-	-	-	
			0.41	660	12.1	5864	5268	5086	4885	4398	3702	-	-	-	-	
		1/2	0.50	715	14.0	6353	5815	5658	5487	5097	4592	-	-	-	-	
			0.54	735	14.7	6531	6011	5861	5699	5332	4877	-	-	-	-	
			0.58	750	15.3	6664	6157	6012	5856	5504	5081	4535	-	-	-	
		3/4	0.60	760	15.7	6753	6254	6112	5959	5617	5212	4686	-	-	-	
			0.75	820	17.9	7286	6831	6704	6570	6276	5941	5577	-	-	-	
			0.80	840	18.6	7464	7021	6898	6770	6489	6170	5804	-	-	-	
	1	0.85	855	19.1	7597	7163	7044	6918	6646	6340	5991	5316	-	-		
		0.90	875	19.8	7775	7352	7237	7116	6855	6562	6234	5600	-	-		
		1.00	905	21	8041	7635	7524	7409	7163	6890	6586	6040	-	-		
	1 1/2	1.10	935	22	8308	7916	7810	7700	7467	7211	6927	6437	-	-		
		1.20	950	22	8441	8057	7953	7845	7618	7369	7094	6625	5559	-		
		1.50	1035	25	9196	8847	8754	8658	8458	8244	8013	7628	6836	-		
	Level 2 Construction	Model L2 24	1/4	1.65	1070	27	9507	9170	9081	8989	8798	8595	8378	8019	7308	-
				1.82	1100	28	9774	9447	9361	9272	9088	8894	8687	8347	7688	6808
				0.25	540	9.9	5317	4075	3362	2733	-	-	-	-	-	-
			1/3	0.27	555	10.9	5464	4290	3707	2948	-	-	-	-	-	-
				0.30	575	12.2	5661	4559	4098	3307	-	-	-	-	-	-
				0.33	590	13.2	5809	4753	4346	3647	-	-	-	-	-	-
1/2			0.36	605	14.3	5957	4943	4574	3995	2908	-	-	-	-	-	
			0.40	630	16.3	6203	5255	4926	4491	3247	-	-	-	-	-	
			0.50	670	17.9	6597	5740	5446	5116	3951	3168	-	-	-	-	
3/4			0.57	685	18.5	6744	5917	5634	5326	4299	3364	2859	-	-	-	
			0.60	700	19.0	6892	6090	5822	5528	4645	3568	3043	-	-	-	
			0.75	740	21	7286	6543	6310	6042	5396	4220	3549	2883	-	-	
1		0.80	765	22	7532	6816	6605	6354	5782	4786	3882	3186	-	-		
		0.86	795	23	7827	7138	6951	6724	6205	5455	4325	3555	-	-		
		0.90	815	24	8024	7350	7177	6964	6471	5827	4716	3807	-	-		
1 1/2		1.00	855	26	8418	7772	7618	7432	6983	6460	5636	4337	-	-		
		1.05	870	27	8566	7930	7779	7604	7170	6677	5958	4551	-	-		
		1.11	890	28	8763	8139	7933	7831	7420	6953	6335	4853	-	-		
2	1.20	910	29	8960	8347	8205	8055	7667	7220	6668	5246	-	-			
	1.50	975	33	9600	9021	8890	8756	8440	8045	7618	6707	4842	-			
	1.66	1015	35	9994	9434	9308	9180	8899	8542	8145	7416	5409	-			
2	1.80	1045	38	10289	9742	9620	9496	9236	8905	8526	7880	5900	-			
	2.00	1075	41	10584	10050	9930	9811	9566	9260	8900	8300	6600	-			
	2.20	1115	46	10978	10459	10343	10229	9995	9724	9396	8848	7521	5700			
			2.37	1145	51	11273	10766	10652	10540	10315	10065	9758	9237	8108	6204	

Performance ratings do not include the effects of appurtenances (accessories).

Power ratings (BHP) do not include transmission losses.

Performance certified is for installation type A-free inlet, free outlet.

The sound ratings shown are loudness values in fan sones @ 5' (1.5m) in a hemispherical free field calculated per AMCA Standard 301. Values shown are for installation Type A-Free inlet fan sone levels.

Due to air stream cooling, the motor loading into the service factor shown does not overheat the motor and is within NEMA recommended limits. BHP at most static pressure points is less than the maximum power shown - in many cases substantially less. Use Optimizer to see the exact BHP for your selection.

Model LC and Model L2 Size 30



Soler & Palau USA, Div. of Soler & Palau Ventilation Group, certifies that the models shown herein are licensed to bear the AMCA Seal. The ratings shown are based on test and procedures performed in accordance with AMCA Publication 211 and AMCA Publication 311 and comply with the requirement of the AMCA Certified Ratings Program.

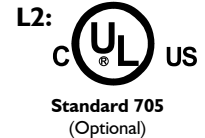

Limits			Panel OD Square	Min. Wall Opening	Damper OD	Approx. Wt
Model	RPM	Motor Frame				
LC	815	145T	36	37 1/2	34 1/2	100
L2	1070	182T	36	37 1/2	34 1/2	180

	Size	Motor HP	Max BHP	Fan RPM	Sones (0.00" SP)	Static Pressure (Inches W.G.)									
						.000	.100	.125	.150	.200	.250	.300	.375	.500	
Level 1 Construction	Model LC 30	1/4	0.25	425	8.3	6956	5509	4962	4215	-	-	-	-	-	
			0.27	435	8.6	7119	5735	5212	4608	-	-	-	-	-	
			0.30	450	9.0	7365	6062	5572	5034	-	-	-	-	-	
		1/3	0.33	465	9.5	7610	6370	5922	5422	-	-	-	-	-	
			0.36	480	9.9	7856	6665	6270	5794	-	-	-	-	-	
			0.40	495	10.5	8101	6954	6603	6152	5073	-	-	-	-	
		1/2	0.50	535	12.0	8756	7709	7419	7074	6211	-	-	-	-	
			0.55	550	12.7	9001	7988	7709	7400	6586	5511	-	-	-	
			0.59	565	13.3	9247	8271	7995	7712	6949	6052	-	-	-	
		3/4	0.75	610	15.3	9983	9117	8839	8589	7995	7242	6351	-	-	
			0.82	630	16.2	10311	9487	9216	8968	8436	7728	6945	-	-	
			0.90	650	17.1	10638	9853	9594	9343	8857	8198	7473	-	-	
		1	1.00	670	18.0	10965	10216	9969	9716	9253	8665	7978	6549	-	
			1.11	695	19.3	11375	10665	10434	10188	9738	9228	8581	7501	-	
			1.20	715	20	11702	11021	10802	10565	10120	9659	9098	8052	-	
		1 1/2	1.50	770	23	12602	11990	11798	11589	11151	10752	10298	9427	-	
			1.63	790	23	12929	12339	12156	11956	11526	11135	10723	9899	8281	
			1.78	815	24	13339	12773	12599	12411	12000	11609	11223	10482	9013	
		Level 2 Construction	Model L2 30	1/3	0.33	480	9.7	7675	6417	5879	5284	-	-	-	-
					0.36	495	10.3	7915	6706	6243	5678	-	-	-	-
0.40	505				10.7	8075	6895	6481	5932	4378	-	-	-		
1/2	0.50			550	12.6	8794	7720	7432	7025	5986	-	-	-		
	0.56			570	13.6	9114	8078	7809	7479	6516	-	-	-		
	0.60			585	14.4	9354	8345	8087	7799	6896	-	-	-		
3/4	0.75			630	17.6	10073	9146	8902	8659	7991	7096	-	-		
	0.83			650	18.4	10393	9499	9258	9026	8455	7609	6642	-		
	0.90			670	19.2	10713	9850	9614	9390	8890	8101	7200	-		
1	1.00			685	19.9	10953	10112	9882	9659	9194	8460	7638	5700		
	1.10			710	21	11352	10546	10325	10106	9672	9068	8284	6802		
	1.20			735	22	11752	10978	10766	10550	10137	9637	8900	7679		
1 1/2	1.50			795	25	12711	12004	11812	11615	11226	10836	10331	9292		
	1.65			820	26	13111	12428	12243	12054	11672	11302	10876	9908		
	1.80			845	27	13511	12851	12673	12490	12116	11760	11378	10510		
2	2.00			875	29	13991	13356	13185	13010	12651	12303	11948	11233	9600	
	2.22			905	31	14470	13859	13696	13528	13183	12840	12504	11907	10399	
	2.40			930	32	14870	14278	14119	13957	13623	13284	12961	12435	11029	
3	3.00			1005	37	16069	15525	15381	15234	14930	14618	14308	13855	12846	
	3.30			1040	41	16629	16105	15967	15825	15534	15235	14930	14495	13600	
	3.60	1070	44	17109	16601	16467	16330	16049	15761	15465	15038	14279			

Performance ratings do not include the effects of appurtenances (accessories).

Power ratings (BHP) do not include transmission losses.

Performance certified is for installation type A-free inlet, free outlet.

The sound ratings shown are loudness values in fan sones @ 5' (1.5m) in a hemispherical free field calculated per AMCA Standard 301. Values shown are for installation Type A-Free inlet fan sone levels.

Due to air stream cooling, the motor loading into the service factor shown does not overheat the motor and is within NEMA recommended limits. BHP at most static pressure points is less than the maximum power shown - in many cases substantially less. Use Optimizer to see the exact BHP for your selection.



Model LC and Model L2 Size 36



Soler & Palau USA, Div. of Soler & Palau Ventilation Group, certifies that the models shown herein are licensed to bear the AMCA Seal. The ratings shown are based on test and procedures performed in accordance with AMCA Publication 211 and AMCA Publication 311 and comply with the requirement of the AMCA Certified Ratings Program.

Limits			Panel OD Square	Min. Wall Opening	Damper OD	Approx. Wt
Model	RPM	Motor Frame				
LC	695	145T	42	43 1/2	40 1/2	105
L2	845	184T	42	43 1/2	40 1/2	215

LC:  Standard 705 (Optional)

L2:  Standard 705 (Optional)

Performance Data

Size	Motor HP	Max BHP	Fan RPM	Sones (0.00" SP)	Static Pressure (Inches W.G)										
					.000	.100	.125	.150	.200	.250	.300	.375	.500	.625	.750
Level 1 Construction Model LC 36	1/3	0.33	360	8.5	9927	7580	6735	5537	-	-	-	-	-	-	-
		0.35	370	8.9	10203	7973	7153	6222	-	-	-	-	-	-	-
		0.41	390	9.7	10755	8745	7976	7190	-	-	-	-	-	-	-
	1/2	0.50	415	10.8	11444	9631	8967	8237	6333	-	-	-	-	-	-
		0.55	430	11.5	11858	10126	9550	8849	7340	-	-	-	-	-	-
		0.59	440	11.9	12133	10449	9923	9248	7840	-	-	-	-	-	-
	3/4	0.75	475	13.7	13098	11556	11133	10611	9337	7872	-	-	-	-	-
		0.82	490	14.5	13512	12022	11620	11162	9954	8675	-	-	-	-	-
		0.90	505	15.3	13926	12485	12100	11686	10557	9348	7384	-	-	-	-
	1	1.00	525	16.4	14477	13103	12731	12348	11345	10187	8897	-	-	-	-
		1.09	540	17.3	14891	13562	13199	12834	11930	10809	9653	-	-	-	-
		1.19	555	18.1	15305	14018	13663	13312	12495	11419	10317	-	-	-	-
	1 1/2	1.50	600	20	16545	15373	15048	14720	14055	13195	12186	10619	-	-	-
		1.58	610	21	16821	15671	15353	15029	14381	13577	12590	11076	-	-	-
		1.79	635	22	17511	16413	16111	15801	15186	14497	13578	12146	-	-	-
	2	2.00	655	23	18062	17003	16713	16415	15819	15189	14366	12975	9909	-	-
		2.22	680	24	18751	17737	17461	17177	16600	16014	15313	13996	11612	-	-
		2.37	695	25	19165	18176	17907	17631	17065	16499	15859	14594	12363	-	-
Level 2 Construction Model L2 36	1/2	0.50	370	10.1	10407	8644	7831	7060	-	-	-	-	-	-	
		0.55	380	10.6	10689	9028	8242	7513	5997	-	-	-	-	-	
		0.60	390	11.1	10970	9391	8667	7941	6466	-	-	-	-	-	
	3/4	0.75	420	12.6	11814	10420	9912	9182	7818	6416	-	-	-	-	
		0.83	435	13.5	12236	10911	10462	9833	8505	7183	-	-	-	-	
		0.90	450	14.3	12658	11390	10989	10460	9156	7800	-	-	-	-	
	1	1.00	465	15.1	13080	11858	11497	11041	9780	8528	7300	-	-	-	
		1.10	480	16.0	13501	12320	11992	11585	10398	9221	8000	-	-	-	
		1.20	495	16.8	13923	12779	12478	12107	11037	9893	8600	-	-	-	
	1 1/2	1.50	530	18.9	14908	13838	13570	13274	12490	11352	10292	8670	-	-	
		1.62	545	19.8	15330	14288	14030	13757	13045	11969	10954	9345	-	-	
		1.79	565	21	15892	14885	14639	14383	13754	12841	11792	10235	-	-	
	2	2.00	585	22	16455	15479	15244	15001	14436	13667	12617	11161	-	-	
		2.20	605	23	17017	16071	15845	15613	15099	14427	13462	12063	9600	-	
		2.39	620	24	17439	16514	16293	16069	15586	14967	14113	12697	10376	-	
	3	3.00	665	27	18705	17836	17631	17425	16998	16506	15886	14557	12404	10213	
		3.30	690	28	19408	18568	18369	18171	17766	17323	16776	15642	13547	11457	
		3.60	715	30	20112	19297	19105	18914	18527	18119	17631	16679	14623	12500	
5	5.00	795	36	22362	21621	21447	21274	20931	20581	20216	19564	17987	16164	14287	
	5.56	825	38	23206	22489	22320	22154	21822	21488	21144	20562	19235	17413	15678	
	5.97	845	40	23768	23067	22902	22739	22415	22090	21757	21214	20010	18237	16588	

Performance ratings do not include the effects of appurtenances (accessories).

Power ratings (BHP) do not include transmission losses.

Performance certified is for installation type A-free inlet, free outlet.

The sound ratings shown are loudness values in fan sones @ 5' (1.5m) in a hemispherical free field calculated per AMCA Standard 301. Values shown are for installation Type A-Free inlet fan sone levels.

Due to air stream cooling, the motor loading into the service factor shown does not overheat the motor and is within NEMA recommended limits. BHP at most static pressure points is less than the maximum power shown - in many cases substantially less. Use Optimizer to see the exact BHP for your selection.

Model LC, Model L2 and Model L3

Size 42



Soler & Palau USA, Div. of Soler & Palau Ventilation Group, certifies that the models shown herein are licensed to bear the AMCA Seal. The ratings shown are based on test and procedures performed in accordance with AMCA Publication 211 and AMCA Publication 311 and comply with the requirement of the AMCA Certified Ratings Program.



Model	Limits		Panel OD Square	Min. Wall Opening	Damper OD	Approx. Wt
	RPM	Motor Frame				
LC	550	145T	48	49 1/2	46 1/2	110
L2	745	184T	48	49 1/2	46 1/2	235
L3	850	213T	48	49 1/2	46 1/2	260

	Size	Motor HP	Max BHP	Fan RPM	Sones (0.10" SP)	Static Pressure (Inches W.G)													
						.000	.100	.125	.150	.200	.250	.300	.375	.500	.625	.750			
Level 1 Construction	Model LC 42	1/3	0.33	285	8.3	12309	8342	6281	-	-	-	-	-	-	-	-			
			0.37	295	8.3	12741	8967	7579	-	-	-	-	-	-	-	-	-		
			0.41	305	8.4	13173	9658	8439	5438	-	-	-	-	-	-	-	-		
		1/2	0.50	325	8.8	14037	10969	9725	8483	-	-	-	-	-	-	-	-		
			0.54	335	9.3	14469	11549	10380	9305	-	-	-	-	-	-	-	-		
			0.60	345	9.8	14901	12109	11073	9960	-	-	-	-	-	-	-	-		
		3/4	0.75	375	11.4	16197	13705	12938	11928	9768	-	-	-	-	-	-	-		
			0.83	385	12.0	16629	14218	13498	12606	10619	-	-	-	-	-	-	-		
			0.90	395	12.6	17060	14724	14044	13252	11285	7292	-	-	-	-	-	-		
		1	1.00	410	13.4	17708	15474	14842	14128	12233	9895	-	-	-	-	-	-		
			1.11	425	14.3	18356	16214	15618	14966	13217	11433	6467	-	-	-	-	-		
			1.20	435	14.9	18788	16703	16128	15508	13911	12182	8485	-	-	-	-	-		
		1 1/2	1.50	470	16.9	20300	18400	17874	17336	16118	14419	12885	-	-	-	-	-		
			1.65	485	17.9	20948	19119	18609	18095	16964	15460	13900	9198	-	-	-	-		
			1.81	500	18.8	21596	19833	19339	18845	17784	16470	14848	11827	-	-	-	-		
		2	2.00	515	19.8	22243	20543	20067	19587	18583	17410	15805	13517	-	-	-	-		
			2.22	535	21	23107	21482	21029	20566	19623	18561	17190	15068	-	-	-	-		
			2.40	550	22	23755	22182	21746	21295	20388	19393	18190	16034	-	-	-	-		
		Level 2 Construction	Model L2 42	1/3	0.33	285	7.8	10509	7477	5671	3612	-	-	-	-	-	-	-	
					0.36	290	8.0	10694	7789	6342	4014	-	-	-	-	-	-	-	-
					0.40	300	8.1	11062	8381	7206	4906	-	-	-	-	-	-	-	-
				1/2	0.50	325	8.9	11984	9671	8755	7643	-	-	-	-	-	-	-	-
					0.55	335	9.4	12353	10149	9347	8304	-	-	-	-	-	-	-	-
					0.60	345	10.0	12722	10621	9901	8910	-	-	-	-	-	-	-	-
3/4	0.75			370	11.5	13644	11823	11131	10411	8367	-	-	-	-	-	-	-		
	0.84			385	12.4	14197	12521	11841	11206	9474	6112	-	-	-	-	-	-		
	0.90			395	13.0	14566	12972	12316	11697	10087	7124	-	-	-	-	-	-		
1	1.00			405	13.7	14934	13406	12803	12178	10697	8279	-	-	-	-	-	-		
	1.10			420	14.6	15487	14041	13516	12889	11606	9898	6533	-	-	-	-	-		
	1.20			435	15.7	16041	14664	14206	13604	12449	10877	8053	-	-	-	-	-		
1 1/2	1.50			470	18.0	17331	16089	15716	15265	14174	13001	11506	7343	-	-	-	-		
	1.66			485	19.0	17884	16689	16339	15942	14884	13846	12428	8858	-	-	-	-		
	1.81			495	19.6	18253	17088	16750	16375	15354	14366	13037	9983	-	-	-	-		
2	2.00			515	21	18990	17880	17564	17222	16325	15345	14250	12166	-	-	-	-		
	2.24			535	22	19728	18666	18369	18052	17271	16299	15368	13458	-	-	-	-		
	2.42			550	23	20281	19253	18969	18666	17959	17006	16121	14360	9183	-	-	-		
3	3.00			590	26	21756	20806	20549	20280	19690	18928	18041	16738	13692	8037	-	-		
	3.33			610	27	22494	21578	21333	21077	20524	19855	18985	17781	15060	9786	6188	-		
	3.60			625	28	23047	22156	21918	21671	21141	20531	19717	18517	15977	11312	7195	-		
5	5.00			700	34	25812	25024	24818	24606	24164	23687	23156	22103	20314	17936	14112	-		
	5.52			720	36	26550	25785	25586	25382	24957	24503	24005	23060	21299	19163	16540	-		
	6.07			745	38	27472	26734	26542	26347	25942	25513	25049	24222	22500	20666	18311	-		
Level 3	Model L3 42			7 1/2	7.50	800	43	29500	28816	28639	28460	28091	27705	27298	26628	25120	23570	21683	
					8.17	825	46	30422	29759	29589	29416	29061	28692	28305	27676	26325	24778	23147	
					8.93	850	48	31344	30701	30537	30369	30027	29673	29304	28710	27497	25965	24512	

Performance ratings do not include the effects of appurtenances (accessories).

Power ratings (BHP) do not include transmission losses.

Performance certified is for installation type A-free inlet, free outlet.

The sound ratings shown are loudness values in fan sones @ 5' (1.5m) in a hemispherical free field calculated per AMCA Standard 301. Values shown are for installation Type A-Free inlet fan sone levels.

Due to air stream cooling, the motor loading into the service factor shown does not overheat the motor and is within NEMA recommended limits. BHP at most static pressure points is less than the maximum power shown - in many cases substantially less. Use Optimizer to see the exact BHP for your selection.

Model LC, Model L2 and Model L3

Size 54



Soler & Palau USA, Div. of Soler & Palau Ventilation Group, certifies that the models shown herein are licensed to bear the AMCA Seal. The ratings shown are based on test and procedures performed in accordance with AMCA Publication 211 and AMCA Publication 311 and comply with the requirement of the AMCA Certified Ratings Program.

Limits			Panel OD Square	Min. Wall Opening	Damper OD	Approx. Wt
Model	RPM	Motor Frame				
LC	425	182T	60	61 1/2	58 1/2	240
L2	515	184T	60	61 1/2	58 1/2	400
L3	740	256T	60	61 1/2	58 1/2	500



Construction	Size	Motor HP	Max BHP	Fan RPM	Sones (0.15" SP)	Static Pressure (Inches W.G)													
						.000	.125	.150	.200	.250	.300	.375	.500	.625	.750				
Level 1 Construction	Model LC 54	3/4	0.75	250	9.8	21652	14977	10311	-	-	-	-	-	-	-	-			
			0.82	260	10.4	22518	16507	13479	-	-	-	-	-	-	-	-	-		
			0.92	270	11.0	23384	17932	15352	10232	-	-	-	-	-	-	-	-		
		1	1.00	275	11.4	23817	18559	16095	11620	-	-	-	-	-	-	-	-		
			1.09	285	12.3	24683	19720	17561	14816	-	-	-	-	-	-	-	-		
			1.20	295	13.1	25550	20825	19097	16699	-	-	-	-	-	-	-	-		
		1 1/2	1.50	315	14.8	27282	22932	21633	19683	12699	-	-	-	-	-	-	-		
			1.61	325	15.5	28148	23950	22757	21183	15785	-	-	-	-	-	-	-		
			1.84	340	16.8	29447	25449	24372	23109	19183	-	-	-	-	-	-	-		
		2	2.00	350	17.7	30313	26434	25414	24259	20671	13599	-	-	-	-	-	-		
			2.19	360	18.5	31179	27408	26437	25365	22133	16456	-	-	-	-	-	-		
			2.38	370	19.4	32045	28375	27445	26439	23692	19651	-	-	-	-	-	-		
		3	3.00	400	22	34643	31236	30401	29530	27543	24351	20039	-	-	-	-	-		
			3.35	415	23	35943	32648	31852	31029	29213	26686	23274	-	-	-	-	-		
			3.60	425	24	36809	33585	32812	32015	30290	28100	24785	15677	-	-	-	-		
		Level 2 Construction	Model L2 54	1	1.00	280	12.9	22680	17068	15430	10747	-	-	-	-	-	-	-	
					1.08	290	12.8	23490	18289	16585	13352	-	-	-	-	-	-	-	-
					1.20	300	13.3	24300	19435	17847	14940	-	-	-	-	-	-	-	-
1 1/2	1.50			325	14.7	26325	22071	20881	18012	15063	-	-	-	-	-	-	-		
	1.66			335	15.3	27135	23051	21991	19167	16645	-	-	-	-	-	-	-		
	1.82			345	15.9	27945	24009	23055	20429	17977	13943	-	-	-	-	-	-		
2	2.00			355	16.5	28755	24951	24076	21693	19167	16320	-	-	-	-	-	-		
	2.14			370	17.4	29970	26337	25543	23506	20904	18665	-	-	-	-	-	-		
	2.42			380	18.1	30780	27250	26496	24642	22110	19943	12875	-	-	-	-	-		
3	3.00			405	19.8	32805	29495	28822	27307	25251	22863	19592	-	-	-	-	-		
	3.26			420	21	34020	30816	30188	28793	27006	24696	21705	-	-	-	-	-		
	3.63			435	22	35235	32123	31538	30237	28662	26595	23500	-	-	-	-	-		
5	5.00			485	27	39285	36430	35924	34861	33677	32300	29567	25066	-	-	-	-		
	5.35			495	28	40095	37284	36789	35763	34624	33339	30803	26276	19008	-	-	-		
	6.04			515	29	41715	38988	38510	37550	36487	35323	33144	28610	24012	-	-	-		
Level 3 Construction	Model L3 54			7 1/2	6.94	540	31	43740	41110	40651	39742	38772	37717	35876	31600	27746	19763		
					7.50	555	33	44955	42378	41930	41046	40126	39121	37436	33508	29564	24604		
					8.60	580	35	46980	44488	44055	43206	42356	41424	39902	36579	32473	28797		
		10	10.00	610	38	49410	47011	46594	45782	44978	44138	42758	39973	36128	32626				
			11.06	630	40	51030	48690	48283	47491	46713	45923	44619	42105	38653	34954				
			12.15	650	42	52650	50364	49967	49195	48439	47682	46454	44142	41077	37264				
		15	15.00	700	48	56700	54541	54164	53434	52725	52024	50955	48962	46617	43558				
			16.45	720	51	58320	56207	55837	55123	54430	53747	52721	50830	48684	45923				
			17.85	740	53	59940	57872	57509	56809	56130	55464	54469	52675	50659	48179				

Performance ratings do not include the effects of appurtenances (accessories).
 Power ratings (BHP) do not include transmission losses.
 Performance certified is for installation type A-free inlet, free outlet.
 The sound ratings shown are loudness values in fan sones @ 5' (1.5m) in a hemispherical free field calculated per AMCA Standard 301. Values shown are for installation Type A-Free inlet fan sone levels.

Due to air stream cooling, the motor loading into the service factor shown does not overheat the motor and is within NEMA recommended limits. BHP at most static pressure points is less than the maximum power shown - in many cases substantially less. Use Optimizer to see the exact BHP for your selection.



Model LC, Model L2 and Model L3

Size 60



Soler & Palau USA, Div. of Soler & Palau Ventilation Group, certifies that the models shown herein are licensed to bear the AMCA Seal. The ratings shown are based on test and procedures performed in accordance with AMCA Publication 211 and AMCA Publication 311 and comply with the requirement of the AMCA Certified Ratings Program.

Limits			Panel OD Square	Min. Wall Opening	Damper OD	Approx. Wt
Model	RPM	Motor Frame				
LC	380	182T	66	67 1/2	64 1/2	285
L2	460	184T	66	67 1/2	64 1/2	490
L3	700	256T	66	67 1/2	64 1/2	530



Performance Data

Construction	Size	Motor HP	Max BHP	Fan RPM	Sones (0.00" SP)	Static Pressure (Inches W.G.)										
						.000	.125	.150	.200	.250	.375	.500	.625	.750	1.000	
Level 1 Construction	Model LC 60	1	1.00	250	10.3	26878	20089	16672	-	-	-	-	-	-	-	
			1.08	255	10.7	27416	20835	18009	-	-	-	-	-	-	-	
			1.21	265	11.5	28491	22275	20109	-	-	-	-	-	-	-	
		1 1/2	1.50	285	13.0	30641	25041	23280	20999	-	-	-	-	-	-	
			1.69	295	13.9	31717	26369	24721	22844	-	-	-	-	-	-	
			1.75	300	14.3	32254	27023	25433	23649	-	-	-	-	-	-	
	2	2.00	310	15.1	33329	28317	26824	25176	18811	-	-	-	-	-		
		2.23	325	16.3	34942	30222	28846	27344	23361	-	-	-	-	-		
		2.44	335	17.1	36017	31464	30159	28751	25399	-	-	-	-	-		
	3	3.03	360	19.1	38705	34490	33367	32125	29373	25314	-	-	-	-		
		3.29	370	20	39780	35672	34618	33430	30822	27531	-	-	-	-		
		3.56	380	21	40855	36826	35849	34723	32244	29351	-	-	-	-		
Level 2 Construction	Model L2 60	1	1.00	250	9.9	25631	17744	15842	-	-	-	-	-	-		
			1.08	260	10.6	26656	19351	17368	-	-	-	-	-	-		
			1.21	270	11.3	27681	20986	18860	15136	-	-	-	-	-		
		1 1/2	1.50	290	12.7	29732	23756	22062	18500	-	-	-	-	-		
			1.67	300	13.4	30757	25033	23639	20021	16501	-	-	-	-		
			1.83	310	14.2	31782	26280	25017	21513	18376	-	-	-	-		
		2	2.00	320	15.0	32808	27513	26324	23013	20017	-	-	-	-		
			2.11	325	15.4	33320	28131	26963	23823	20803	-	-	-	-		
			2.22	330	15.8	33833	28744	27594	24667	21569	-	-	-	-		
	3	3.00	365	19.0	37421	32929	31915	29813	26912	19530	-	-	-			
		3.38	380	20	38959	34674	33724	31731	29390	22561	-	-	-			
		3.64	390	21	39984	35821	34914	32979	30912	24209	-	-	-			
	5	5.00	435	25	44598	40862	40121	38488	36744	31031	25399	-	-			
		5.60	450	26	46136	42519	41809	40275	38594	33461	27901	-	-			
		5.98	460	27	47161	43618	42926	41454	39830	35125	29479	-	-			
Level 3 Construction	Model L3 60	7 1/2	7.03	485	29	49724	46353	45700	44359	42869	38864	33248	28162	-		
			7.50	495	30	50749	47441	46803	45502	44065	40196	34740	29870	-		
			7.91	505	31	51774	48527	47902	46633	45252	41497	36241	31497	-		
		10	9.09	530	34	54338	51231	50636	49437	48180	44658	40368	35343	30623	-	
			10.00	545	35	55875	52847	52268	51107	49912	46512	42747	37583	33176	-	
			10.78	560	37	57413	54459	53895	52767	51617	48365	44872	39824	35577	-	
		15	11.98	580	39	59464	56603	56058	54969	53868	50812	47513	43039	38629	-	
			15.00	625	44	64077	61406	60896	59886	58874	56189	53177	50021	45397	37596	
			16.48	645	47	66128	63532	63037	62056	61078	58529	55646	52673	48763	40825	
				17.98	665	49	68178	65654	65173	64219	63271	60843	58098	55240	51973	43894

Performance ratings do not include the effects of appurtenances (accessories).

Power ratings (BHP) do not include transmission losses.

Performance certified is for installation type A-free inlet, free outlet.

The sound ratings shown are loudness values in fan sones @ 5' (1.5m) in a hemispherical free field calculated per AMCA Standard 301. Values shown are for installation Type A-Free inlet fan sone levels.

Due to air stream cooling, the motor loading into the service factor shown does not overheat the motor and is within NEMA recommended limits. BHP at most static pressure points is less than the maximum power shown - in many cases substantially less. Use Optimizer to see the exact BHP for your selection.

Model L3

Size 72



Soler & Palau USA, Div. of Soler & Palau Ventilation Group, certifies that the models shown herein are licensed to bear the AMCA Seal. The ratings shown are based on test and procedures performed in accordance with AMCA Publication 211 and AMCA Publication 311 and comply with the requirement of the AMCA Certified Ratings Program.

Limits			Panel OD Square	Min. Wall Opening	Damper OD	Approx. Wt
Model	RPM	Motor Frame				
L3	545	256T	80	81 1/2	78 1/2	600



Standard 705
(Optional)

Size	Motor HP	Max BHP	Fan RPM	Sones (0.00" SP)	Static Pressure (Inches W.G)										
					.000	.125	.200	.250	.300	.375	.500	.625	.750	1.000	
Level 3 Construction Model L3 72	1 1/2	1.29	225	22	35129	20805	-	-	-	-	-	-	-	-	-
		1.50	235	23	36690	23490	11736	-	-	-	-	-	-	-	-
		1.77	250	25	39032	28557	16766	-	-	-	-	-	-	-	-
	2	2.00	260	27	40593	30797	19872	12185	-	-	-	-	-	-	-
		2.23	270	28	42154	33105	22720	15591	-	-	-	-	-	-	-
		2.36	275	29	42935	34370	23988	17268	-	-	-	-	-	-	-
	3	3.00	295	34	46058	38778	28928	23480	16818	-	-	-	-	-	-
		3.22	305	36	47619	40624	32722	26224	20149	-	-	-	-	-	-
		3.54	315	39	49180	42421	35839	28644	23303	-	-	-	-	-	-
	5	4.26	335	44	52303	45927	40304	34243	28943	20547	-	-	-	-	-
		5.00	350	48	54645	48505	44011	39490	32581	25385	-	-	-	-	-
		5.98	375	56	58548	52752	49397	45162	40602	32470	19719	-	-	-	-
	7	6.44	385	60	60109	54439	52140	47621	43710	34888	23115	-	-	-	-
		7.50	405	64	63232	57793	54820	52395	48197	39949	29577	17215	-	-	-
		8.71	425	67	66354	61123	58310	56291	52989	47294	35402	24005	-	-	-
	10	10.00	445	69	69477	64435	61744	59908	57687	52162	40392	30620	19305	-	-
		11.04	460	71	71819	66908	64294	62555	60633	55471	44092	35242	24397	-	-
		12.15	475	74	74160	69373	66838	65165	63387	59202	48920	39535	29471	-	-
	15	15.00	510	79	79625	75100	72720	71154	69590	66984	59376	48219	40396	-	-
		16.41	525	81	81967	77547	75223	73700	72190	69767	62695	52353	44585	26079	-
		18.36	545	85	85089	80799	78545	77078	75619	73370	67480	59891	49467	32867	-

Performance ratings do not include the effects of appurtenances (accessories).

Power ratings (BHP) do not include transmission losses.

Performance certified is for installation type A-free inlet, free outlet.

The sound ratings shown are loudness values in fan sones @ 5' (1.5m) in a hemispherical free field calculated per AMCA Standard 301.

Values shown are for installation Type A-Free inlet fan sone levels.

Due to air stream cooling, the motor loading into the service factor shown does not overheat the motor and is within NEMA recommended limits. BHP at most static pressure points is less than the maximum power shown - in many cases substantially less. Use Optimizer to see the exact BHP for your selection.



Wall Collar and Optional Accessories

Wall Collar

The heavy-gauge, all G-90 galvanized mounting collar provides a simple solution to installing a fan in a rough wall opening when a rear safety guard is **NOT** required. A front wire guard, shutter, and/or rainhood can be attached to the front prepunched flanges. The wall collar can be used in exhaust or supply applications for all fan sizes. The wall collar is mounted with the fan on the interior side of the building. All collars ship fully assembled with the fan to lessen jobsite installation costs. We strongly recommend rainhoods and motorized shutter for all supply applications as well as for exhaust applications where additional weather protection is desired.

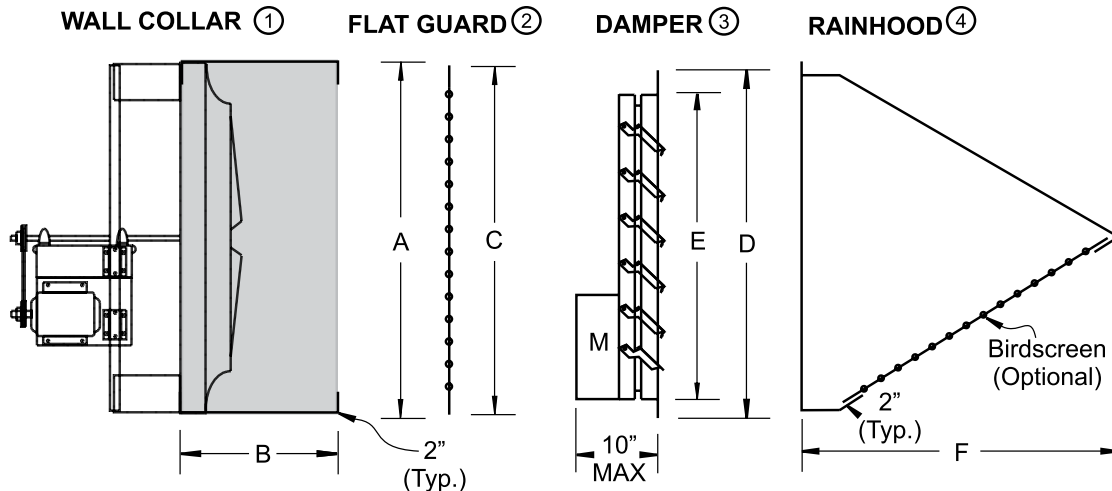

Accessories Dimensions

Fan Size	Wall Collar ①		Minimum Wall Opening	Flat Guard ②	Damper ③		Rainhood ④	Motorside Guard ⑤	
	A	B	Sq	C	D (O.D)	E	F	G Exh/Sup	H Exhaust/Supply
20	24 1/4	21	25 1/2	24	22 1/2	20	24 1/4	24	34
24	30 1/4	21	31 1/2	30	28 1/2	26	28 1/2	30	34
30	36 1/4	21	37 1/2	36	34 1/2	32	34 1/2	36	34
36	42 1/4	21	43 1/2	42	40 1/2	38	40 1/2	42	34
42	48 1/8	21	49 1/2	48	46 1/2	44	46 1/2	48	34
48	54 1/8	21	55 1/2	54	52 1/2	50	49 1/2	54	34
54	60 1/8	21	61 1/2	60	58 1/2	56	58 1/2	60	34
60	66 1/8	21	67 1/2	66	64 1/2	62	64 1/2	66	34
72	80 1/8	26	81 1/2	80	78 1/2	76	73	80	34

(a) Level 3 Construction requires a deeper motorside guard as shown. Unless shown otherwise supply and exhaust dimensions are similar.

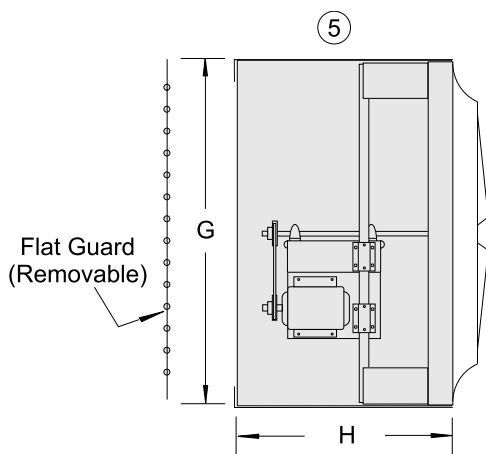

Sheet Metal and Wire Motorside Guard

An assembled heavy-gauge G-90 galvanized steel housing is available with front or rear OSHA approved flat wire safety guard with 1/2 x 1 in. galvanized welded wire. This housing and guard attaches to the fan panel. It ships pre-assembled to lessen installation costs, but is available knocked-down for field assembly. Optional heavy-duty OSHA approved guard is constructed of heavy-gauge aluminum expanded metal. Please note that this style guard is not compatible with the wall collar or wall housing. Adequate clearance must be maintained between fan blade and damper.

Wall Housing and Optional Accessories

WALL HOUSING

This heavy-gauge, all galvanized G-90 steel housing provides a simple solution to installing a fan and all required accessories in a rough wall opening. It can be used in exhaust or supply applications and in fan sizes 20 through 72 inch. Depending on space and maintenance requirements, the wall housing may be installed inward or outwards of the building. All housings ship assembled with the fan to lessen job site installation costs. Wire guards, shutters and/or rainhoods may be attached to the pre-punched flange. See pages 16-19 for available accessories. We strongly recommend rainhoods and motorized shutters for all supply applications and whenever additional weather protection is desired..

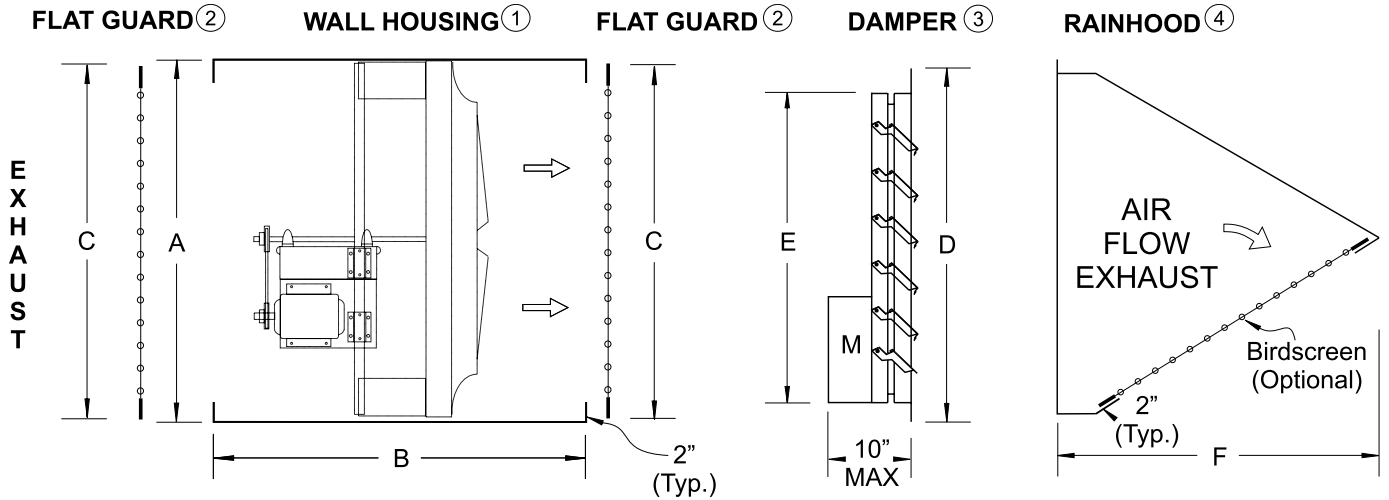

Fan Size	Wall Housing ①					Minimum Wall Opening (Sq)	Flat Guard ② C (Sq)	Damper ③		Rainhood ④ F
	A (Sq.) O.D.	B Length						D (O.D)	E	
		Exhaust		Supply						
		Level 1	Levels 2 & 3	Level 1	Levels 2 & 3					
20	25	32 (1)	44	44	44	25 1/2	24	22 1/2	20	24 1/4
24	31	32 (1)	44	44	44	31 1/2	30	28 1/2	26	28 1/2
30	37	32 (1)	44	44	44	37 1/2	36	34 1/2	32	34 1/2
36	43	32 (1)	44	44	44	43 1/2	42	40 1/2	38	40 1/2
42	49	32 (1)	44	44	44	49 1/2	48	46 1/2	44	46 1/2
48	55	32 (1)	44	44	44	55 1/2	54	52 1/2	50	49 1/2
54	61	44	44	44	44	61 1/2	60	58 1/2	56	58 1/2
60	67	44	44	44	44	67 1/2	66	64 1/2	62	64 1/2
72	81	NA	44	NA	44	81 1/2	80	78 1/2	76	73

Note (1) - 44" long wall housing required when optional motorized damper is selected.

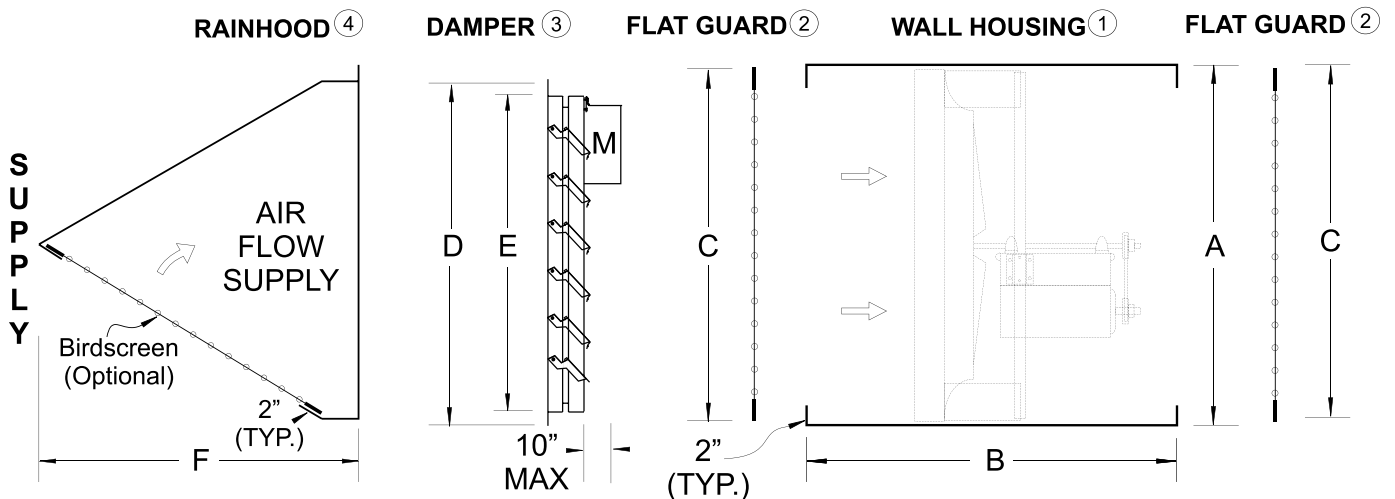

Rainhood recommended for supply applications.



SIDEWALL PROPELLER FAN ACCESSORIES & OPTIONS



Heavy-Duty Galvanized Exhaust Motorized Shutter: This damper has a flanged frame and is designed to fit the inside flanges of the optional wall housing or wall mounting collar. The frame and blades are constructed of galvanized steel and are rated to 3000 FPM with proper clearance as provided by all factory accessories. The damper body recesses into the opening for a flush appearance. See page 19 for more details on the electric damper operators.

Standard Duty Aluminum Exhaust Gravity Shutter: This damper can greatly reduce the infiltration of outside air and although not completely watertight, will provide weather protection in an economical fashion. Constructed with a galvanized frame and aluminum blades this damper is rated to 2000 FPM with the proper clearance as provided by all factory accessories. The damper body is recessed into the opening for a flush appearance.

Heavy-Duty Galvanized Supply Motorized Shutter: The motorized option improves weather protection by providing a tighter closure seal and is recommended for all supply applications. Heavy-duty dampers are constructed with galvanized frames and blades and are rated to 3000 FPM. The damper body is not recessed providing extra clearance between the fan and damper blades. See page 19 for more details on the electric damper operators.



Standard Duty Aluminum Supply Motorized Shutter: The motorized option improves weather protection by providing a tighter closure seal and is recommended for all supply applications. Standard duty dampers are constructed with galvanized frames and aluminum blades and are rated to 2000 FPM. The damper body is not recessed providing extra clearance between the fan and damper blades. See page 19 for more details on the electric damper operators.

Center Pivot Motorized Damper - Supply or Exhaust: The flanged frame damper is designed to recess inside the flanges of the optional wall housing or wall mounting collar. The center pivot style damper provides superior weather resistance. Galvanized (optional aluminum) construction is rated to 3500 FPM with proper clearance as provided by all factory accessories. See page 19 for more details on the electric damper operators.

Rainhoods or Weatherhoods: Designed to provide additional weather protection by partially shielding the wall opening and should be used for all supply applications and whenever additional weather resistance is desired. The galvanized (aluminum optional) hood attaches to the wall housing or wall collar flanges. Field flashing and caulking will reduce moisture penetration. Shown with optional birdscreen.

SIDEWALL PROPELLER FAN ACCESSORIES & OPTIONS

Safety Guards are strongly recommended to protect personnel from accidental injury and to prevent debris from entering the fan. OSHA approved guards are required in many installations including when the fans are within 7 feet of the floor or work/access area.

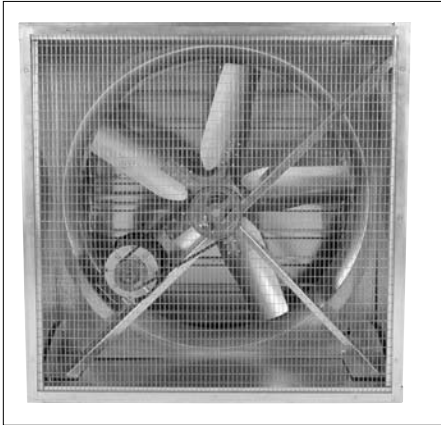

Standard Duty Flat Wire Guard: The removable safety guard satisfies OSHA requirements when used with the optional wall housing as a motorside (rear) guard. The 16 ga. 1/2" X 1" welded wire mesh is mounted in a galvanized frame and attaches to the inward flanges of the wall housing.

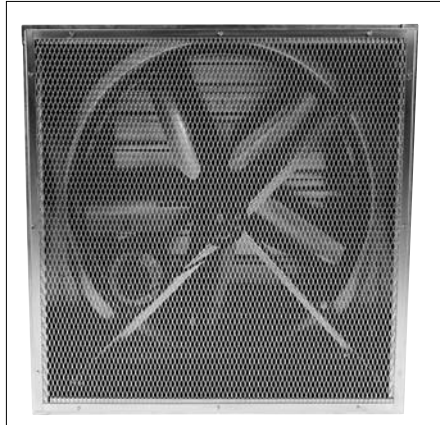

Heavy-Duty Flat Wire Guard: The removable safety guard satisfies OSHA requirements when used with the optional wall housing as a motorside (rear) guard. The H.D. expanded aluminum mesh is mounted in a galvanized frame and attaches to the inward flanges of the wall housing.

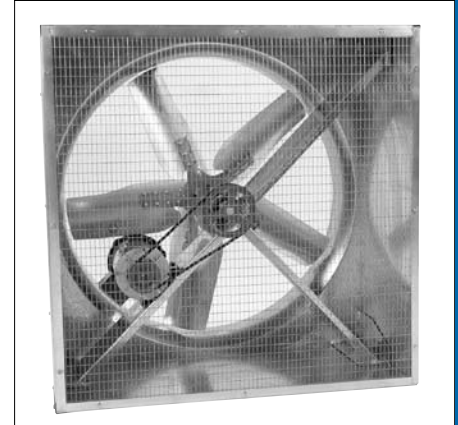

Sheet Metal and Wire Motorside Guard: The OSHA approved safety guard consists of galvanized sides (aluminum optional) plus a flat wire guard (standard duty or heavy-duty) factory assembled and attached to motorside (rear) of the fan panel. This guard is **not** compatible with the wall housing or wall mounting collar.

Electric Damper Operators provide more positive open and closed damper positions which helps increase weather resistance. Power open - spring close (POSC) motor and linkage kits are field installed (except for center pivot style) and are available in 24, 120/240, or 460 volts (single phase) and require approximately 0.5 amps at 120/1/60 power supply. Transformers are available for voltage reduction. For fan motors 5HP and larger, we recommend a factory tilt switch or "delay-on" timer in the control circuit (by others) to allow the damper to open prior to allowing fan operation, which will protect the damper blades and fan from damage when the fan is first energized.

Electrical Accessories are available to simplify the installation and reduce the total project cost.

Disconnect Switches can be shipped loose or factory mounted and wired (except explosion proof and two speed) in NEMA 1, 3R, 4X, or other enclosures. Two-speed and explosion proof disconnects are available but may be subject to more stringent code requirements. It is the responsibility of the buyer and the installer to comply with all local and national codes.

Aluminum Construction is available for most models and typically includes propeller blades, fan panel, motor and drive support (large frame motors may have steel reinforcement) and accessories. When an explosion proof motor is specified, aluminum fan construction must be used for additional spark resistance.

cULus 705 or UL 705 Listing is available for sidewall propeller fans with most motors and should be specified for electrical safety and reliability.

Extended Lube Lines provide convenient access for routine bearing lubrication. Lubrication lines are installed from the fan shaft bearings to the exterior of the wall housing or sheet metal motorside guard and are provided with zerk fittings.

Paints and Coatings include protective and corrosion resistant coatings such as air-dry two part epoxy, phenolic (Heresite) and synthetic resin (Eisenheiss), as well as decorative color finishes to match the building (a paint chip is required to match). Please note that our standard construction material specifications are almost exclusively G90 galvanized steel and may not require any additional coating.

Mounting Angles facilitate the installation and a secure attachment of the wall housing or wall collar into the framed wall opening. Galvanized or aluminum angles are available and are pre-cut to the proper length. Additional bracing, mounting hardware, flashing and caulking are typically provided by the installer.

Factory Wiring can simplify jobsite installation and reduce the overall project cost. Optional services include wiring of motor, disconnect switch, damper actuator, and other custom controls. Please note that some wiring options may not be available in conjunction with the cULus 705 and UL 705 listing option (for example explosion proof, two speed and special motors).

Additional Products

Soler & Palau manufactures a complete line of gravity ventilators and fans for all your ventilation requirements.



MODEL DB
Backward Inclined
Belt Drive
Centrifugal Roof Exhaust



MODEL RED
Backward Inclined
Direct Drive
Centrifugal Roof Exhaust



MODEL SQB/SQD
Backward Inclined
Belt Drive/Direct Drive
Square Inline



MODEL UBB/UBX/UBS
Propeller
Belt and Direct Drive
Upblast Roof Exhaust



MODEL L
Propeller
Belt Drive
Sidewall Exhaust or Supply



MODEL BGH
Gravity Hood
Intake or Relief



MODEL KSF
Forward Curved Blower
Belt Drive
Filtered Roof Supply



MODEL TXB/TXD
Backward Inclined
Belt Drive/Direct Drive
Centrifugal Upblast

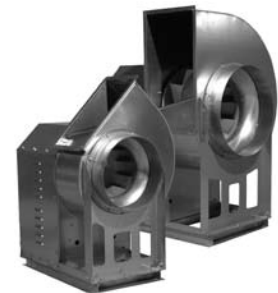

MODEL BVS
Backward Inclined
Belt Drive
Centrifugal Utility Set

DUE TO CONTINUING RESEARCH SOLER & PALAU RESERVES THE RIGHT TO CHANGE SPECIFICATIONS WITHOUT NOTICE

Distributed By:



Soler & Palau Canada
61 A Baywood Road
Toronto, ON M9V 3Y8
866.733.0233
866.358.5346
www.solerpalaucanada.com