

CWD Sidewall Centrifugal Exhausters

Direct Drive

Catalog CWD01-July 2007



The World's Leading Producer of
Air Movement Products



Soler & Palau USA, Div. of Soler & Palau Ventilation Group, certifies that the Models CWD shown herein are licensed to bear the AMCA Seal. The ratings shown are based on test and procedures performed in accordance with AMCA Publication 211 and AMCA Publication 311 and comply with the requirement of the AMCA Certified Ratings Program.

Soler&Palau  Ventilation Group

COMMERCIAL PRODUCT LINE



Model CWD Direct Drive Centrifugal Sidewall Exhausters

Application

Models CWD are high capacity sidewall mounted centrifugal exhaust fans rated from 170 to 3360 CFM, with static pressure capabilities to 1 inch. They are used to exhaust relatively clean air from a variety of industrial, commercial and institutional buildings such as machinery and equipment rooms, storage areas, office buildings, restaurants, retail stores, schools and similar buildings.

The nonoverloading backward inclined centrifugal wheel with its high static pressure capability, makes it suitable for either ducted or nonducted applications. It should be used where a sidewall mounted location is preferred to roof mounting.

The spun aluminum exterior provides a pleasing appearance, weatherproof construction and resistance to corrosion. The low silhouette design is less noticeable on the building exterior and the removable dome provides easy access to the fan interior for service and cleaning.

Model CWD is compatible with belt driven Model DB and companion gravity units to make up a complete ventilation system. Direct drive units use smaller diameter wheels with lower rpm's, resulting in low sound levels and quiet operation. They have no belts or fan bearings to maintain or adjust and consequently require very little maintenance.

Construction/Specification Checklist

Housing

- Integral spun inlet for efficient performance.
- Spun aluminum dome for weather protection and attractive appearance.
- Motor support of heavy-gauge aluminum for rigidity and strength.
- Ventilated motor compartment with motor out of air stream for long trouble-free service.
- Dome easily removes for access to motor compartment.
- Water-tight construction.
- Duct connection provided at wheel inlet.

Centrifugal Wheel

- Backward inclined for efficiency at higher static pressure.
- Nonoverloading for safe operation in ducted systems.
- Statically and dynamically balanced for smooth, quiet operation.
- Heavy aluminum hub for extra strength.
- All aluminum construction.

Motors

- Speed controllable motors available on most models.
- Brands are nationally recognized and locally serviced.
- Single speed open drip-proof are standard.
- Two speed drip-proof and single speed explosion-proof motors are available for most models.
- Disconnect switch standard with single speed drip-proof motors (except explosion proof and two speed units).

AMCA Seal

- Models CWD are licensed for Air and Sound Performance.

UL Label

- UL 705 available when specified.

Options/Accessories

Solid State Speed Control: Available with direct drive models. Control is matched to the motor and blower wheel to allow reduction in performance from full motor speed to 60% of full speed. CFM is reduced in direct proportion to motor speed reduction. Exhauster performance can be controlled from the ventilated area.

Automatic Damper: Automatic (gravity operated) damper for ease in installation and effective backdraft protection.

Aluminum Birdscreen: Integrated birdscreen provides protection from birds and other objects. Easily removable to allow access to wheel.

Epoxy Finish: Epoxy forms an excellent hard, heavy film barrier against chemical attack as well as physical damage from direct impact and abrasion.

Other Finishes: Heresite and Eisenheiss are also available when special coatings are required.

Quickship Program

All CWD Models and many optional accessories are available on the Quickship Program. This program provides rapid delivery of standard products so that tight project deadlines can be met and downtime on replacement work can be held to a minimum. Visit www.solerpalaucanada.com to see the latest Quickship catalog.

Optisizer Fan Selection Program

Please refer to Soler & Palau's Optisizer program for fan curve, submittal information, and other details of the CWD series and other Soler & Palau products. Visit www.solerpalaucanada.com to download your copy.

All specifications are subject to change without notice unless approved in submittal by Soler & Palau.

Model CWD

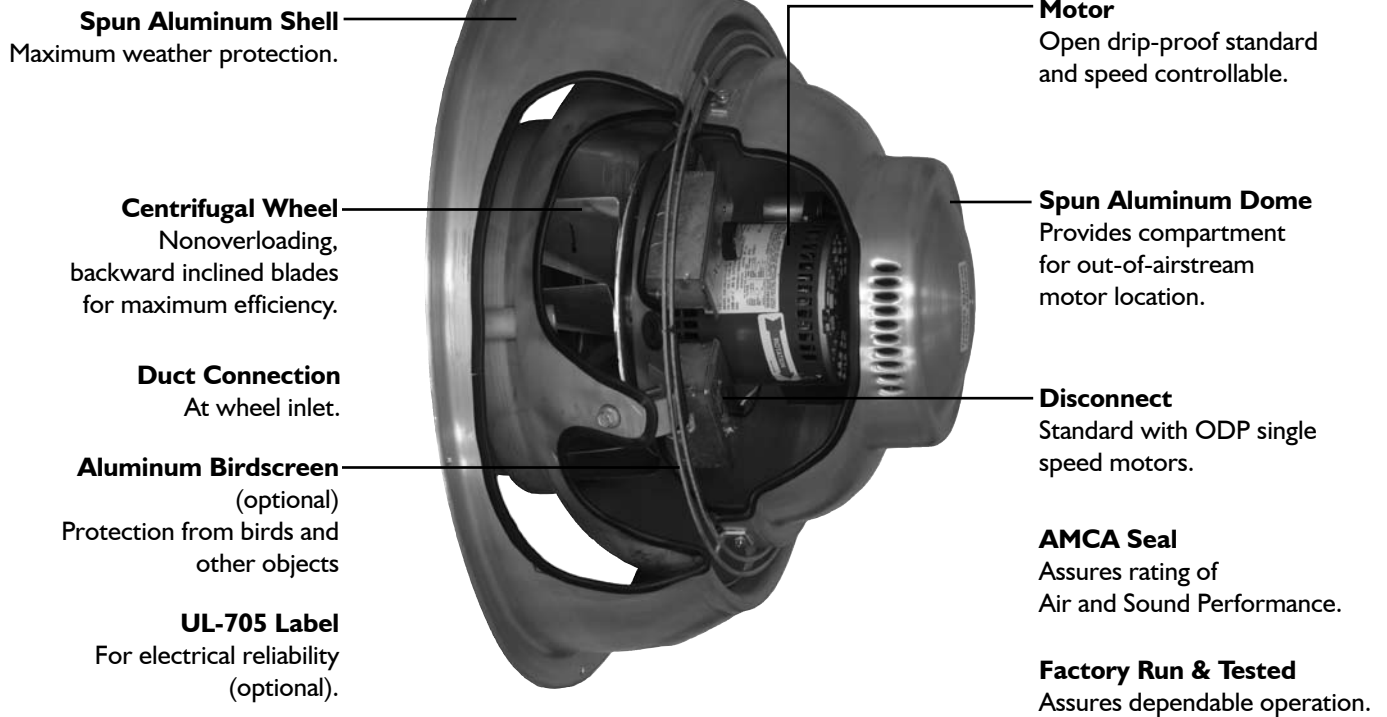

Typical Specifications

Sidewall exhaust fan shall be of the centrifugal direct drive type. Units shall be constructed of aluminum for durability and appearance. Units shall have a deep spun venturi inlet to help prevent the entry of snow and rain into the building.

Fan wheels shall be of the centrifugal backward inclined type, constructed of all aluminum and containing a matching inlet venturi for optimum unit performance. Wheels shall be statically and dynamically balanced.

Motor assembly shall be isolated from unit to eliminate vibration and noise transmission. Motor and wheel assemblies shall be removable as a complete module without complete disassembly of the unit for service and maintenance. Motors shall be mounted out of the exhaust airstream and cooled by air separate from the exhaust. Motors for use with speed

control shall be closely matched to the fan load and provide good speed controllability without any objectionable noise. Motor shall contain thermal overload protection and be UL705 listed.

A disconnect shall be provided on all standard single speed ODP motors. A conduit chase shall be provided through to the motor compartment.

Fans shall bear the AMCA ratings seal for Air and Sound Performance. Fans shall bear a permanently attached nameplate displaying model and serial number of unit for future identification.

Fans shall be Models CWD as manufactured by Soler & Palau USA, in Jacksonville, Florida.

SOLER & PALAU USA LIMITED WARRANTY

Soler & Palau USA (manufacturer), 6393 Powers Avenue, Jacksonville, Florida 32217, warrants the CWD to be free from defects in design, materials and workmanship (exclusive of abrasion, corrosion or erosion) for five (5) years from the date of shipment to the original purchaser or the date of notification of readiness to ship. Motor warranty is one (1) year. In order to claim the benefit of this warranty, buyer must notify manufacturer in writing of the claimed defect within ten (10) days after discovering it and return the equipment or parts to the factory with transportation prepaid. In the event of on-site repair, no service technician will be dispatched until manufacturer receives your written purchase order. If any of the following conditions exist, the warranty will be null and void: **(1)** Buyer has permitted other persons not approved or authorized by manufacturer to alter, adjust, replace or repair the equipment or any part thereof. **(2)** Buyer has not followed instructions or other directions given in the contract documents or our maintenance manual. **(3)** When breakage or other loss or damage is the result of any negligence, misuse or fault on the part of any operator or other person not under our supervision or control. **(4)** The defect is the result of designs or drawings made, furnished or specified by others. **(5)** In the case of goods not manufactured but supplied by the manufacturer as part of a contract, manufacturer shall only be liable to the same extent that our supplier is to manufacturer, not to exceed any liability manufacturer would have for warranty on our own equipment. **(6)** Buyer has not paid in full any invoices submitted to buyer which are due for payment. **(7)** Unusual wear and tear of the equipment. Statements relating to the product, its use or installation made prior to the execution of the agreement, are not warranties except to the extent that the contrary is expressly set forth herein. It is understood that such statements were not intended to, and did not, form a part of the agreement; they were merely made in the course of negotiations of the parties. **THIS WARRANTY IS IN LIEU OF ANY OTHER EXPRESS OR IMPLIED WARRANTIES, INCLUDING ANY IMPLIED WARRANTY OF MERCHANTABILITY OR FITNESS FOR ANY PARTICULAR PURPOSE. OUR SOLE AND EXCLUSIVE OBLIGATION UNDER THIS WARRANTY IS TO REPAIR OR REPLACE DEFECTIVE EQUIPMENT OR PARTS OR, AT OUR OPTION, TO PAY THE REASONABLE COST OF REPAIR OR REPLACEMENT. BUYER AGREES THAT NO OTHER REMEDY (INCLUDING, BUT NOT LIMITED TO, INCIDENTAL OR CONSEQUENTIAL DAMAGES, DAMAGES FOR LOST PROFITS OR SALES, OR DAMAGES FOR INJURIES TO PERSON OR PROPERTY) SHALL BE AVAILABLE. NOTWITHSTANDING THE ABOVE, THE TOTAL AMOUNT THAT MAY IN ANY EVENT BE PAYABLE IN SETTLEMENT OF LIABILITY, HOWEVER INCURRED, SHALL NOT EXCEED THE CONTRACT PRICE.**



Performance/Dimensions

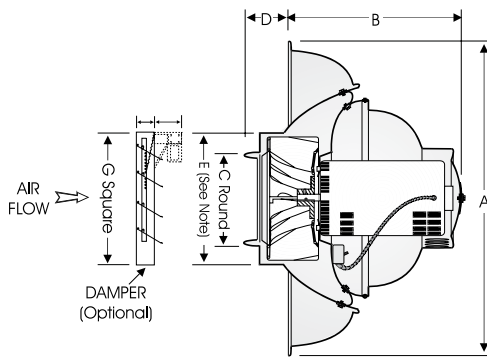

DIMENSIONAL DATA							
Size	A	B	C	D	E	G	Avg. Ship Wt. (lbs.)
7	15	8	5-15/16	1-1/2	8	8	12
8	20	9	9-15/16	2	12	11	20
9	26	13-1/2	11-15/16	3	15	14	37

SIZES 7, 8 & 9

	CFM / BHP @ Static Pressure / Sones									HP	RPM	Tip Speed
	0	1/8	1/4	3/8	1/2	5/8	3/4	7/8	1			
CWD 7	152 .02/2.3	84 .01/1.5	-	-	-	-	-	-	-	1/25	930	1723
	175 .02/3.1	120 .02/2.3	-	-	-	-	-	-	-	1/25	1070	1982
	202 .02/4.1	156 .02/3.4	93 .02/3.2	-	-	-	-	-	-	1/25	1230	2279
	228 .03/5.2	189 .03/4.6	139 .03/4.1	75 .02/4.3	-	-	-	-	-	1/25	1390	2575
	254 .04/6.5	220 .04/5.9	179 .03/5.3	127 .03/5.3	66 .03/5.4	-	-	-	-	1/25	1550	2871
CWD 8	320 .03/4.0	209 .02/3.5	98 .02/4.0	-	-	-	-	-	-	1/15	930	2267
	369 .04/5.0	275 .03/4.7	175 .02/5.0	-	-	-	-	-	-	1/15	1075	2620
	421 .05/6.7	339 .04/6.4	251 .04/6.3	167 .03/6.8	-	-	-	-	-	1/15	1225	2986
	473 .06/8.9	403 .06/8.5	324 .05/8.2	243 .05/8.3	172 .04/8.7	92 .04/9.1	-	-	-	1/15	1375	3352
	524 .07/11.8	463 .07/11.4	390 .06/11.1	320 .06/10.7	249 .05/10.9	186 .04/11.1	132 .04/11.4	-	-	1/15	1550	3778
CWD 9	540 .03/2.5	258 .02/1.9	-	-	-	-	-	-	-	1/4	685	2004
	630 .05/3.5	392 .04/2.9	-	-	-	-	-	-	-	1/4	800	2340
	741 .08/4.9	554 .06/4.3	330 .05/4.0	-	-	-	-	-	-	1/4	940	2750
	804 .09/5.7	637 .08/5.1	426 .07/4.7	236 .05/4.6	-	-	-	-	-	1/4	1020	2984
	898 .12/7.0	755 .11/6.4	564 .09/5.9	390 .08/5.8	221 .07/5.6	-	-	-	-	1/4	1140	3335
	811 .09/6.1	651 .08/5.6	467 .07/4.8	313 .06/4.7	-	-	-	-	-	1/4	1030	3012
	965 .14/8.1	834 .13/7.5	687 .12/7.0	528 .10/6.4	401 .09/5.8	-	-	-	-	1/4	1225	3583
	1083 .19/9.7	970 .18/9.2	842 .17/8.7	704 .16/8.2	565 .14/7.8	454 .12/7.4	-	-	-	1/4	1375	4021
	1221 .26/12.1	1126 .25/11.4	1009 .25/10.9	894 .23/10.5	771 .22/10.2	645 .20/9.8	545 .18/9.5	-	-	1/4	1550	4534
	1320 .34/13.8	1255 .33/13.4	1149 .32/13.1	1047 .31/12.8	937 .30/12.5	823 .28/12.1	709 .26/11.6	617 .24/11.6	532 .23/11.5	1/3	1700	4973

Performance certified is for installation type A - free inlet, free outlet.
 Performance ratings include the effects of birdscreen in the airstream.
 The sound ratings shown are loudness values in fan sones @ 5' (1.5m) in a hemispherical free field calculated per AMCA Standard 301. Values shown are for free inlet fan sone levels.

* Base Unit- AMCA Seal for Sound Rating does not apply to units with speed control.
 S RPM range capable with solid state speed control.

Speed (RPM) shown is nominal. Performance is based on actual speed of test.

Note: For round duct connection directly to unit without damper, cut a circular hole equal to dimension E above.



Soler & Palau USA, Div. of Soler & Palau Ventilation Group, certifies that the Models CWD shown herein are licensed to bear the AMCA Seal. The ratings shown are based on test and procedures performed in accordance with AMCA Publication 211 and AMCA Publication 311 and comply with the requirement of the AMCA Certified Ratings Program.



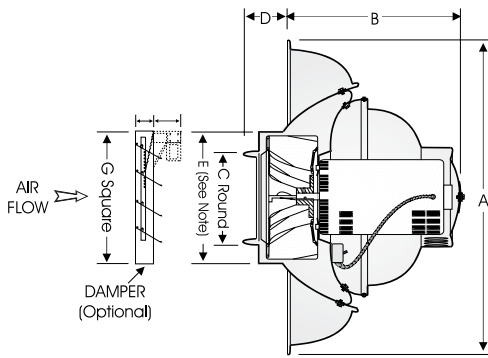

DIMENSIONAL DATA							
Size	A	B	C	D	E	G	Avg. Ship Wt. (lbs.)
10	26	13-1/2	11-15/16	3	15	14	37
11	30	15-1/2	13-15/16	3	17-1/2	14	50

SIZES 10 & 11

	CFM / BHP @ Static Pressure / Sones									HP	RPM	Tip Speed
	0	1/8	1/4	3/8	1/2	5/8	3/4	7/8	1			
CWD 10	629 .04/3.0	326 .03/2.6	-	-	-	-	-	-	-	1/4	685	2093
	734 .05/4.2	474 .04/3.7	224 .04/3.6	-	-	-	-	-	-	1/4	800	2444
	826 .07/5.3	618 .07/4.9	369 .05/4.7	142 .05/4.6	-	-	-	-	-	1/4	900	2750
	936 .10/6.7	773 .10/6.3	527 .08/6.1	335 .07/6.0	128 .06/6.0	-	-	-	-	1/4	1020	3116
	1046 .14/8.1	903 .13/7.7	682 .11/7.5	503 .10/7.4	329 .09/7.4	143 .08/7.3	-	-	-	1/4	1140	3483
	950 .10/7.5	794 .09/7.2	540 .08/6.5	357 .07/5.7	173 .06/5.4	-	-	-	-	1/3	1030	3147
	1107 .15/9.7	976 .15/9.3	777 .12/9.0	581 .11/8.2	427 .10/7.5	274 .09/6.8	-	-	-	1/3	1200	3666
	1268 .23/12.2	1155 .22/12.0	1028 .20/11.8	813 .18/11.3	657 .16/10.5	523 .15/9.7	391 .14/9.1	250 .13/9.0	-	1/3	1375	4201
	1453 .33/15.6	1355 .33/15.4	1252 .32/15.3	1118 .30/15.2	921 .26/14.7	785 .24/13.8	663 .23/13.0	548 .21/12.3	433 .20/11.6	1/3	1575	4812
	1591 .45/18.1	1502 .44/18.0	1409 .43/17.9	1308 .42/17.8	1144 .38/17.7	981 .34/17.0	859 .32/16.2	748 .31/15.6	642 .29/14.9	1/2	1725	5269
CWD 11	810 .06/3.9	525 .05/3.3	240 .04/3.1	-	-	-	-	-	-	1/4	705	2291
	919 .08/5.3	684 .07/4.6	410 .06/4.5	164 .06/4.3	-	-	-	-	-	1/4	800	2600
	1034 .11/6.5	837 .11/6.0	579 .09/5.7	362 .08/5.6	134 .08/5.4	-	-	-	-	1/4	900	2925
	1171 .16/8.1	1019 .15/7.5	783 .14/7.2	571 .13/7.1	382 .11/7.0	183 .11/6.9	-	-	-	1/4	1020	3315
	1309 .24/9.7	1182 .23/9.2	981 .21/8.7	772 .19/8.6	595 .17/8.6	427 .16/8.5	251 .15/8.4	-	-	1/4	1140	3705
	1162 .14/9.1	1010 .13/8.6	813 .12/7.8	620 .11/6.9	439 .08/6.6	-	-	-	-	1/2	1030	3348
	1354 .22/11.6	1243 .21/11.1	1069 .19/10.6	900 .18/9.6	733 .17/8.7	577 .15/8.6	-	-	-	1/2	1200	3900
	1495 .29/13.5	1405 .28/13.1	1245 .26/12.6	1095 .25/11.8	941 .23/11.0	792 .22/10.9	651 .20/10.8	-	-	1/2	1325	4306
	1636 .38/15.6	1560 .37/15.2	1419 .35/14.8	1281 .33/14.4	1140 .32/13.5	1001 .30/12.6	865 .29/11.8	736 .28/11.6	-	1/2	1450	4713
	1805 .50/18.4	1741 .49/18.0	1624 .48/17.7	1493 .45/17.3	1370 .44/16.8	1242 .42/15.9	1116 .39/15.0	991 .38/14.4	873 .36/13.6	1/2	1600	5200

Performance certified is for installation type A - free inlet, free outlet.
 Performance ratings include the effects of birdscreen in the airstream.
 The sound ratings shown are loudness values in fan sones @ 5' (1.5m) in a hemispherical free field calculated per AMCA Standard 301. Values shown are for free inlet fan sone levels.

* Base Unit- AMCA Seal for Sound Rating does not apply to units with speed control.

S RPM range capable with solid state speed control.

Speed (RPM) shown is nominal. Performance is based on actual speed of test.

Note: For round duct connection directly to unit without damper, cut a circular hole equal to dimension E above.



Soler & Palau USA, Div. of Soler & Palau Ventilation Group, certifies that the Models CWD shown herein are licensed to bear the AMCA Seal. The ratings shown are based on test and procedures performed in accordance with AMCA Publication 211 and AMCA Publication 311 and comply with the requirement of the AMCA Certified Ratings Program.



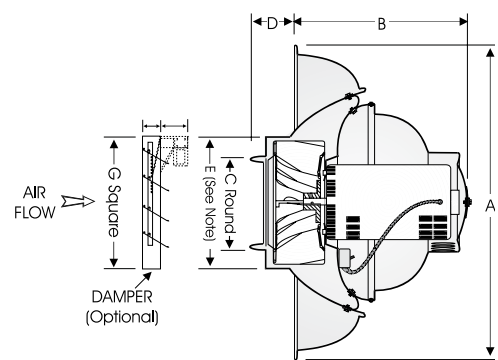

DIMENSIONAL DATA							
Size	A	B	C	D	E	G	Avg. Ship Wt. (lbs.)
12	30	15-1/2	13-15/16	3	17-1/2	14	50
14	36	16-1/2	17-15/16	4	22	18	84
16	36	16-1/2	17-15/16	4	22	18	84

SIZES 12, 14 & 16

	CFM / BHP @ Static Pressure / Sones									HP	RPM	Tip Speed
	0	1/8	1/4	3/8	1/2	5/8	3/4	7/8	1			
CWD 12	986 .07/5.4	670 .06/3.6	365 .05/3.1	-	-	-	-	-	-	1/4	685	2471
	1152 .12/6.9	885 .10/5.4	621 .09/4.1	348 .08/4.5	-	-	-	-	-	1/4	800	2886
	1296 .15/8.5	1058 .13/7.0	816 .12/5.8	589 .11/5.3	340 .10/5.8	-	-	-	-	1/4	900	3247
	1439 .21/10.2	1227 .20/8.7	1007 .17/7.4	801 .15/6.5	591 .13/6.5	363 .13/7.0	-	-	-	1/4	1000	3608
	1583 .26/12.0	1393 .25/10.6	1195 .24/9.2	995 .22/8.3	813 .20/7.4	618 .18/7.8	410 .18/8.3	193 .17/8.8	-	1/4	1100	3968
	1640 .14/7.0	1382 .12/6.7	913 .10/6.2	498 .09/5.5	-	-	-	-	-	1/2	685	2939
CWD 14	1915 .21/9.2	1714 .20/8.8	1366 .18/8.4	971 .15/7.6	614 .14/6.8	-	-	-	-	1/2	800	3432
	2154 .30/11.4	1987 .29/11.0	1730 .27/10.7	1346 .25/10.1	1028 .22/9.5	711 .21/8.8	390 .20/8.7	-	-	1/2	900	3861
	2394 .41/13.7	2249 .40/13.4	2049 .38/13.1	1749 .35/12.8	1407 .32/12.3	1124 .28/11.7	839 .27/11.2	551 .26/10.7	-	1/2	1000	4290
CWD 16	2585 .50/15.9	2454 .49/15.7	2281 .47/15.3	2040 .44/15.0	1722 .41/14.7	1433 .38/14.2	1170 .36/13.8	906 .34/13.3	670 .33/12.9	1/2	1080	4633
	3360 .75/19.2	3158 .73/18.3	2937 .72/17.4	2669 .68/16.5	2349 .63/15.7	2005 .58/14.6	1692 .54/13.5	1364 .49/12.4	1032 .44/11.6	3/4	1140	4835

Performance certified is for installation type A - free inlet, free outlet. Performance ratings include the effects of birdscreen in the airstream. The sound ratings shown are loudness values in fan sones @ 5' (1.5m) in a hemispherical free field calculated per AMCA Standard 301. Values shown are for free inlet fan sone levels.

* Base Unit- AMCA Seal for Sound Rating does not apply to units with speed control.
S RPM range capable with solid state speed control.

Speed (RPM) shown is nominal. Performance is based on actual speed of test.
Note: For round duct connection directly to unit without damper, cut a circular hole equal to dimension E above.



Soler & Palau USA, Div. of Soler & Palau Ventilation Group, certifies that the Models CWD shown herein are licensed to bear the AMCA Seal. The ratings shown are based on test and procedures performed in accordance with AMCA Publication 211 and AMCA Publication 311 and comply with the requirement of the AMCA Certified Ratings Program.



Chemical Resistance Chart



REAGENT INVOLVED	PAINT SYSTEM				
	NON-COATED 3003 ALLOY ALUMINUM	AIR DRIED ALKYL ENAMEL	BAKED EPOXY	SYNTHETIC RESIN (EISENHEISS)	PHENOLIC (HERESITE)
MAXIMUM TEMPERATURE	300°F	200°F	250°F	300°F	140°F
ABRASION (DRY)	U	S	S	F	F
MOISTURE (WATER)	S	S	S	S	S
SATURATED STEAM	S	S	S	S	U
SALT SPRAY	L	L	S	S	F
ACETIC ACID	L	S	S	S	F
ACETONE	S	U	S	U	F
ALCOHOLS	S	S	S	S	F
ALUMINUM CHLORIDE	U	S	S	S	F
ALUMINUM SULPHATE	U	S	S	S	F
AMMONIA GAS	N	S	S	N	N
AMMONIUM CHLORIDE	U	S	S	F	F
AMMONIUM HYDROXIDE	F	S	S	F	U
AMMONIUM NITRATE	F	N	S	S	L
AMMONIUM SULPHATE	U	S	S	S	L
BENZENE	S	N	S	U	F
BLEACHING COMPOUNDS	N	F	N	N	N
BORIC ACID	U	S	S	S	F
BROMINE	L	S	F	N	N
BUTANOL	N	N	S	S	F
BUTYRIC ACID	F	N	S	N	N
CALCIUM CARBONATE	S	S	S	N	N
CALCIUM CHLORIDE,WET	U	N	N	F	F
CALCIUM CHLORIDE,DRY	U	S	S	S	F
CALCIUM HYDROXIDE	U	S	S	F	F
CALCIUM HYPOCHLORITE	U	N	N	S	U
CARBOLIC ACID	F	U	F	U	F
CARBON DISULPHIDE	S	U	S	U	F
CARBON MONOXIDE	S	S	S	N	N
CARBON TETRACHLORIDE	L	U	S	U	F
CARBONIC ACID	F	S	S	S	F
CHLORINE, WET OR HOT	U	N	F	N	N
CHLORINE, DRY	U	S	S	S	F
CHLOROBENZENE	N	N	N	N	F
CHLOROFORM	F	F	S	N	N
CHROMIC ACID	U	S	F	F	U
CITRIC ACID	L	S	S	S	F
COPPER SULPHATE	U	N	N	S	F
ETHANOL	N	N	S	S	F
ETHYL ACETATE	N	N	S	F	F
ETHYLENE DICHLORIDE	N	N	F	F	F
ETHYLENE GLYCOL	F	N	N	F	F
FERRIC CHLORIDE	U	N	N	S	F
FERRIC SULPHATE	U	N	N	S	F

REAGENT INVOLVED	PAINT SYSTEM				
	NON-COATED 3003 ALLOY ALUMINUM	AIR DRIED ALKYL ENAMEL	BAKED EPOXY	SYNTHETIC RESIN (EISENHEISS)	PHENOLIC (HERESITE)
MAXIMUM TEMPERATURE	300°F	200°F	250°F	300°F	140°F
FORMALDEHYDE	F	N	S	N	F
FORMIC ACID	U	F	N	N	F
GASOLINE	F	S	S	S	F
HYDROBROMIC ACID	L	S	F	N	N
HYDROCHLORIC ACID	U	S	F	S	F
HYDROCHLORUS ACID	L	S	F	N	N
HYDROFLUORIC ACID	U	U	F	U	U
HYDROGEN PEROXIDE	F	S	S	F	U
HYDROGEN SULPHIDE	L	N	S	F	F
LACQUER SOLVENTS	S	U	S	N	N
LACTIC ACID	U	S	L	S	F
LINSEED OIL	N	N	S	S	S
METHANOL	N	N	F	F	F
METHYL ETHYL KETONE	S	N	S	U	F
METHYL ISOBUTYL KETONE	S	N	F	U	F
MINERAL SPIRITS	N	N	S	F	F
NITRIC ACID	U	S	S	F	U
NITROUS ACID	F	S	S	N	N
OLEIC ACID	S	S	S	N	N
PETROLEUM ETHER	N	N	F	F	F
PHOSPHORIC ACID	U	S	S	S	F
POTASSIUM ALUM	N	N	N	S	F
POTASSIUM CYANIDE	L	S	S	N	N
POTASSIUM HYDROXIDE	U	S	S	F	U
POTASSIUM DICHROMATE	N	N	N	N	F
POTASSIUM NITRATE	N	N	S	N	N
PYROGALLIC ACID	F	N	S	N	N
SODIUM BISULPHATE	L	N	N	S	F
SODIUM CHLORIDE	L	N	S	S	F
SODIUM CYANIDE	L	S	S	N	N
SODIUM HYDROXIDE	U	S	S	F	U
SODIUM HYPOCHLORITE	U	N	N	F	U
SODIUM SULPHATE	S	N	N	S	F
SULPHURIC ACID	U	S	S	F	F
SULPHUROUS ACID	L	S	S	S	F
SULPHUR DIOXIDE	U	S	S	F	F
SULPHUR TRIOXIDE	U	L	S	N	N
TANNIC ACID	L	S	S	S	S
TOLUENE	S	U	S	U	F
TRICHLOROETHYLENE	F	N	S	U	F
VINEGAR	L	N	N	S	U
XYLOL	S	U	S	F	F

S - Suitable for heavy concentrations of fumes, including splash or condensation.

F - Suitable for mild concentrations of fumes, but no splash or condensation.

L - Suitable for light corrosion service, or intermittent exposure to light fume concentration. Not suitable if moisture, splash or condensation are present.

U - Unsatisfactory for use against corrosive agent listed.

N - No data available.

NOTE: Data presented is a summary of corrosion resistance characteristics of aluminum and the four coating systems shown. While single "letter" rating and a single temperature cannot possibly describe all situations, this data is presented as a guide. Caution must be exercised where moisture and/or temperature along with a chemical reagent will be encountered.

Additional Products

Soler & Palau manufactures a complete line of gravity ventilators and fans for all your ventilation requirements.



MODEL DB
Backward Inclined
Belt Drive
Centrifugal Roof Exhaust



MODEL RED
Backward Inclined
Direct Drive
Centrifugal Roof Exhaust



MODEL SQB/SQD
Backward Inclined
Belt Drive/Direct Drive
Square Inline



MODEL UBB/UBX/UBS
Propeller
Belt and Direct Drive
Upblast Roof Exhaust



MODEL L
Propeller
Belt Drive
Sidewall Exhaust or Supply

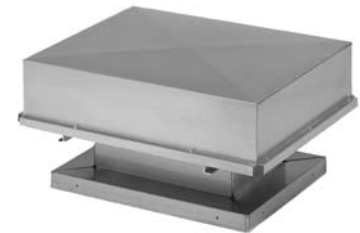

MODEL BGH
Gravity Hood
Intake or Relief



MODEL KSF
Forward Curved Blower
Belt Drive
Filtered Roof Supply



MODEL TXB/TXD
Backward Inclined
Belt Drive/Direct Drive
Centrifugal Upblast

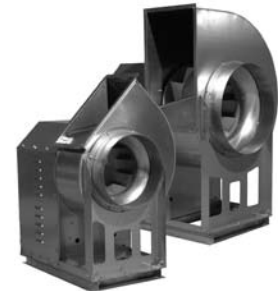

MODEL BVS
Backward Inclined
Belt Drive
Centrifugal Utility Set

DUE TO CONTINUING RESEARCH SOLER & PALAU RESERVES THE RIGHT TO CHANGE SPECIFICATIONS WITHOUT NOTICE

Distributed By:



Soler & Palau Canada
61 A Baywood Road
Toronto, ON M9V 3Y8
866.733.0233
866.358.5346
www.solerpalaucanada.com